



NEMOTO & CO.,LTD

1-15-1, Kamiogi, Suginami-ku, Tokyo 167-0043, Japan  
Tel. 81-3-3392-7181 Fax. 81-3-3392-7188  
e-mail : intsales@nemoto.co.jp

(Apr 11, 2001)

USER'S MANUAL FOR NAP-78A  
CATALYTIC TYPE INCOMPLETE COMBUSTION SENSOR

NEMOTO's NAP-78A is a newly developed catalytic type gas sensor designed to detect incomplete combustion of domestic water heaters to be installed indoors. Constant monitoring of the combustion conditions of a water heater is possible by installing an exclusively designed detecting unit with NAP-78A in a flue duct. When incomplete combustion occurs, the unit will put out signals proportional to incomplete combustion levels (CO gas concentration levels in a flue gas).

## 1. Applications

- \* FF type water heaters (Forced draught balanced Flue type)
- \* FE type water heaters (Forced Exhaust type)
- \* Water heaters for air conditioning
- \* Gas/Oil heaters

## 2. Features

- \* Temperature compensation is unnecessary in the wide range from room temperature to 200°C.
- \* Depending on the kinds of fuel gases and their combustion conditions, the ratio of H<sub>2</sub> gas and CO gas generated upon incomplete combustion varies in the range of 1:1 to 4:1 (CO:H<sub>2</sub>). However NAP-78A is applicable to almost of all fuel gases because of its relatively low hydrogen gas dependency characteristic.
- \* Excellent reproducibility and stability.
- \* Superior accuracy such as 300 ppm of CO gas in a flue gas can be detected.
- \* Small humidity dependency in a flue gas.
- \* Small-sized, lightweight, and less-expensive.
- \* Distinguished long term stability and durability.
- \* Easy calibration because of small individual differences in production lots.
- \* More than 10-year life was confirmed by accelerated tests using actual water heating equipment.
- \* Excellent corrosion resistivity.
- \* Superior durability to silicone and H<sub>2</sub>S gas.



NEMOTO & CO.,LTD

1-15-1, Kamiogi, Suginami-ku, Tokyo 167-0043, Japan  
Tel. 81-3-3392-7181 Fax. 81-3-3392-7188  
e-mail: intsales@nemoto.co.jp

### 3. Incomplete combustion

It is known that hydrogen gas is generated in addition to carbon monoxide gas upon incomplete combustion of hydro-carbon fuels, and a ratio of these two gases varies depending on the kinds of gases and appliances used as well as combustion energies of fuels. According to test results by K.H.K. (The High Pressure Gas Safety Institute of Japan) and J.I.A. (Japan Gas Appliances Inspection Association), the ratio of CO:H<sub>2</sub> is between 1:1 and 4:1. This test result indicates that it is important to detect H<sub>2</sub> gas also in addition to CO gas for monitoring incomplete combustion. When a detecting unit with NAP-78A is installed in a water heater, CO + H<sub>2</sub> gas concentrations in a flue gas can be constantly monitored to integrate the time and the concentration so that a controlling unit automatically shuts off the operation or controls the combustion conditions. In case of domestic water heaters installed indoors, it is required to detect a level of 500ppm of CO gas to prevent ambient pollution. NAP-78A is able to detect this level of environmental pollution.

### 4. Maximum rating ;

Supply voltage : D.C. 3.0V

Ambient temperature & humidity :

In operation: Temperature ; Less than +260°C  
Humidity ; Less than 99% RH (Temp. - less than 100°C)

For storage : Temperature ; -30 to +70°C  
Humidity ; Less than 98% RH (without dew condensation)  
Air velocity ; Less than 3 m/sec.

### 5. Rating ;

Upon monitoring :

Supply voltage ; D.C. 2.0V +/- 0.1V  
Current ; 130 to 150 mA (When 2.0V is supplied)

Upon heat cleaning :

Supply voltage ; D.C. 2.75V +/- 0.05V  
Current ; 170 to 190 mA (When 2.75V is supplied)

Heat cleaning cycle ; for 30 seconds just after switch-on

Ambient temperature & humidity :

In operation: Temperature ; -10 to +200°C  
Humidity ; Less than 95% RH (Temp. - less than 100°C)

For storage : Temperature ; -20 to +60°C  
Humidity ; Less than 98% RH (without dew condensation)

Air velocity : Less than 1 m/sec.



NEMOTO & CO.,LTD

1-15-1, Kamiogi, Suginami-ku, Tokyo 167-0043, Japan  
Tel. 81-3-3392-7181 Fax. 81-3-3392-7188  
e-mail : intsales@nemoto.co.jp

## 6. Structure

Shown on the attached drawing No. 1. Almost of the parts of this sensor are made of stainless steel for better durability to the expected severer application environment, and the base plate, lead wires, and fillers shall withstand up to 300 °C .

An exclusively designed detecting unit, NAP-78A, is available, and technical information on this detecting unit is provided separately.

## 7. Characteristics

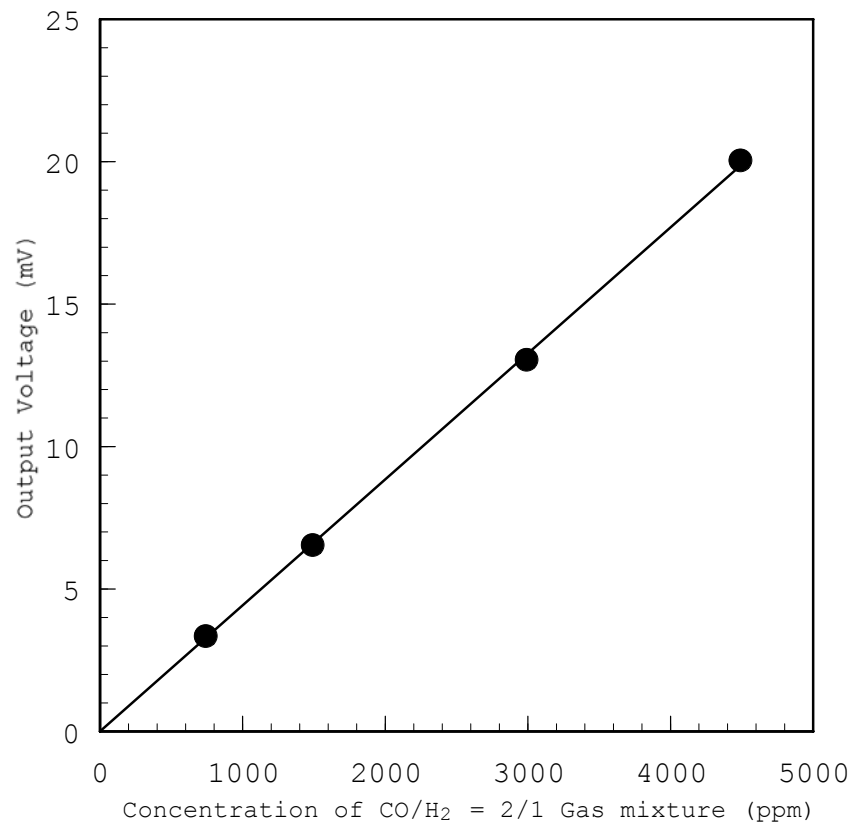

\* Gas sensitivity in room temperature



Since 1941

NEMOTO & CO.,LTD

1-15-1, Kamiogi, Suginami-ku, Tokyo 167-0043, Japan

Tel. 81-3-3392-7181 Fax. 81-3-3392-7188

e-mail : intsales@nemoto.co.jp

\* Temperature dependency

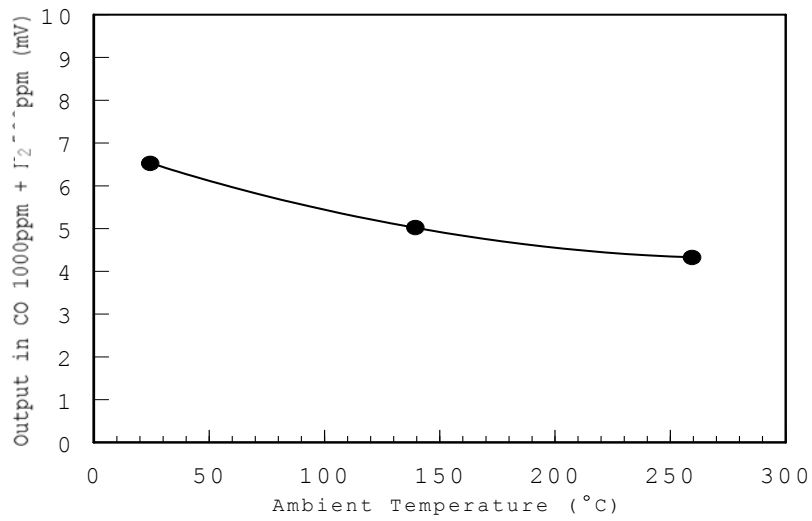
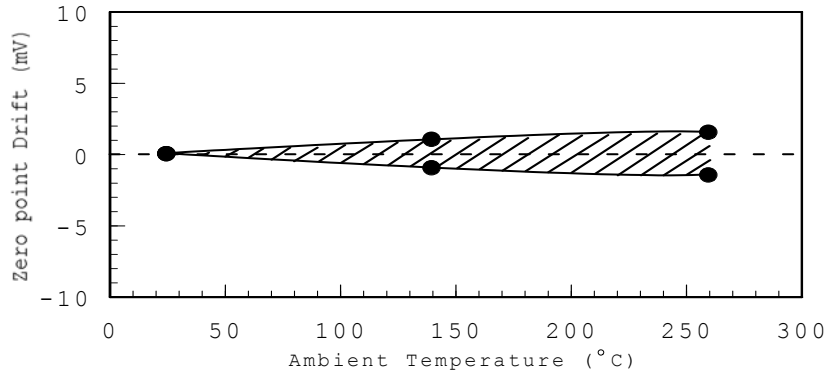

\* Hydrogen gas dependency

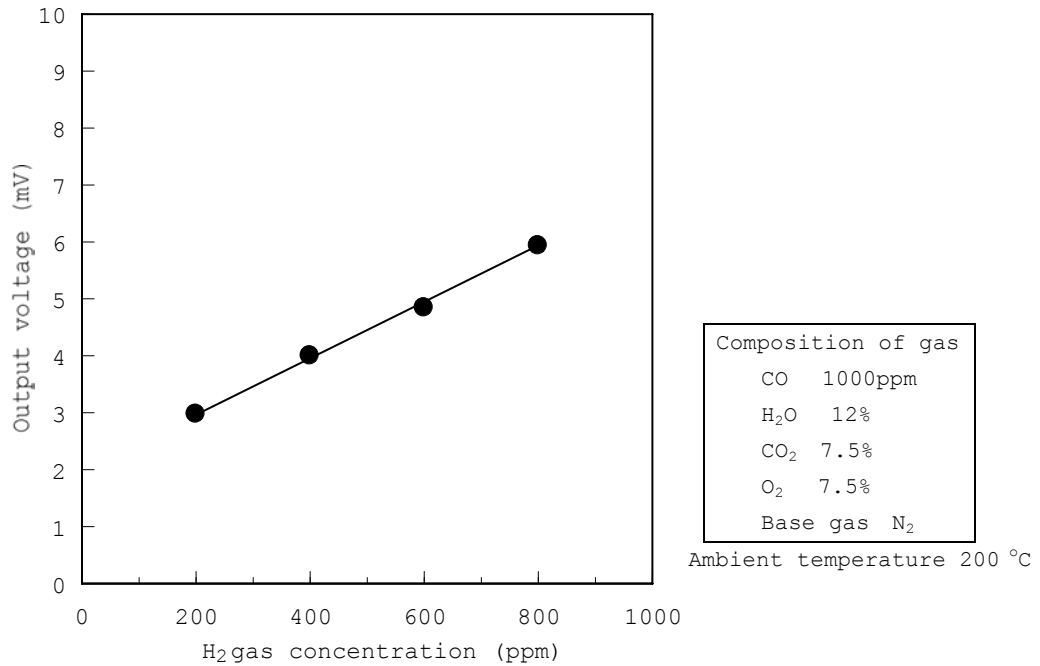



NEMOTO & CO.,LTD

1-15-1, Kamiogi, Suginami-ku, Tokyo 167-0043, Japan

Tel. 81-3-3392-7181 Fax. 81-3-3392-7188

e-mail : intsales@nemoto.co.jp

\* Oxygen gas dependency

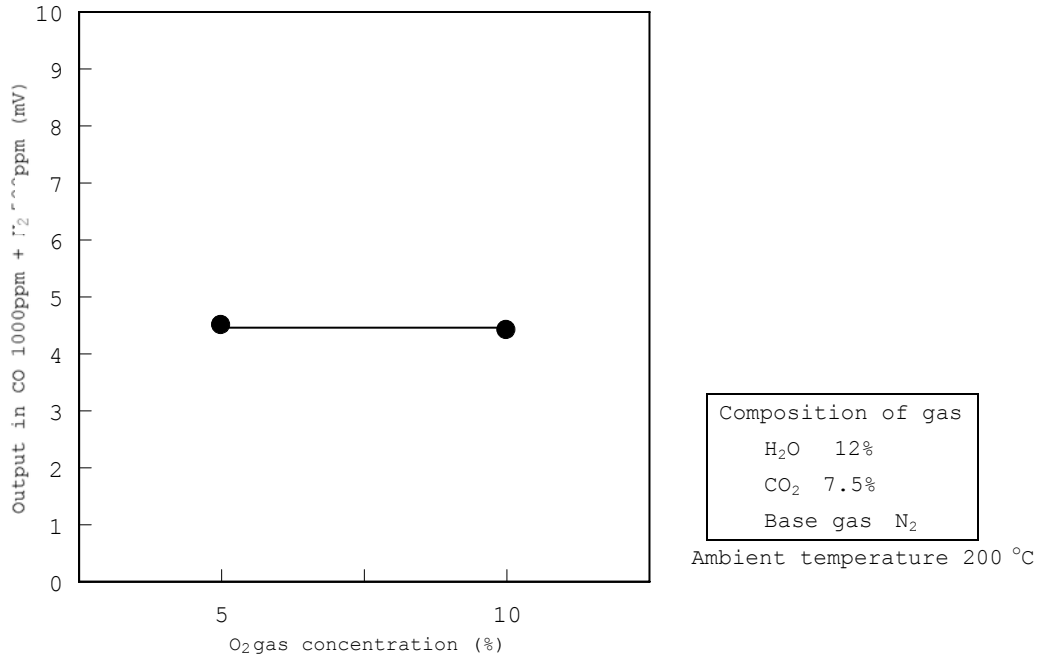

\* Initial stability characteristics

The chart shows the characteristics of a sensor after stored for a month without electrified. Generally, 90% recovery is obtained within 1 minute after re-electrified.

Example of measurement

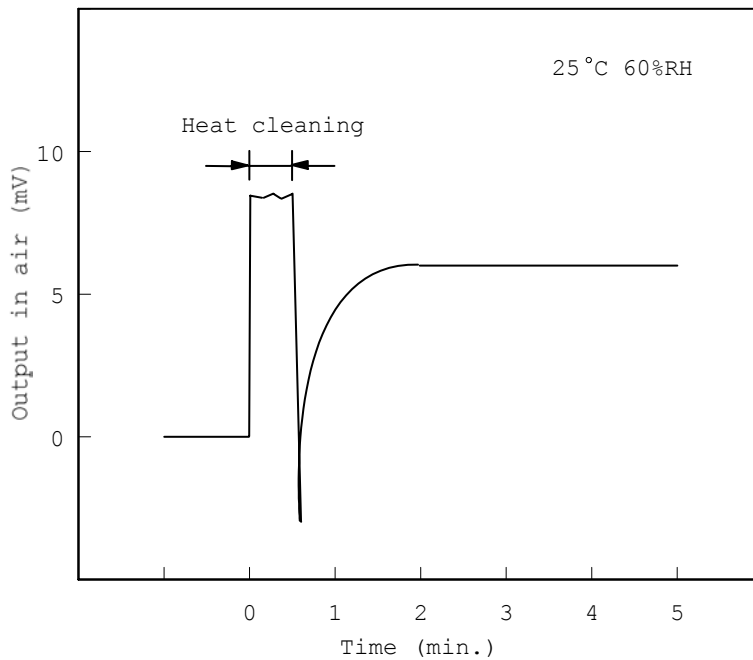



NEMOTO & CO.,LTD

1-15-1, Kamiogi, Suginami-ku, Tokyo 167-0043, Japan  
Tel. 81-3-3392-7181 Fax. 81-3-3392-7188  
e-mail: intsales@nemoto.co.jp

\* Field test results

(Durability tests on sensors assembled in actual water heaters)

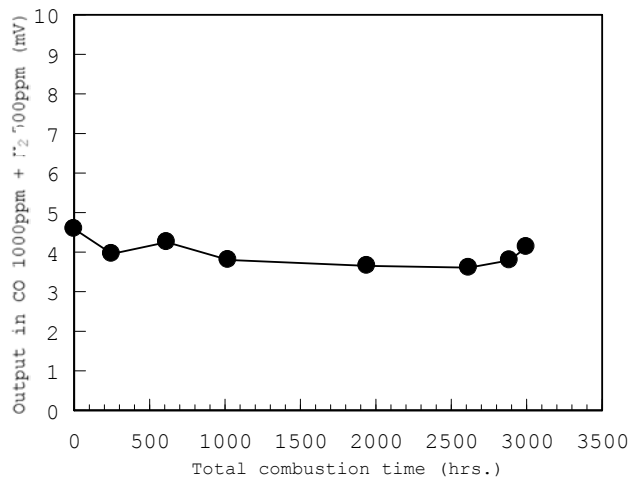
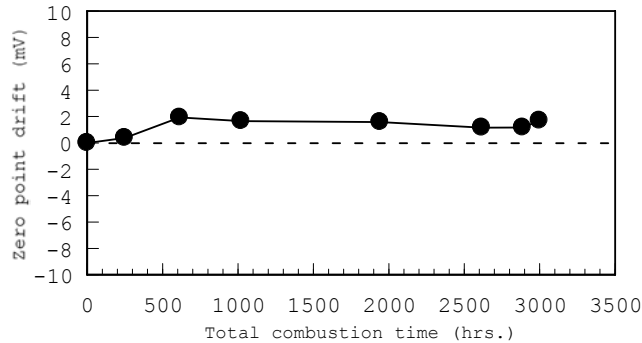

Composition of gas	
H <sub>2</sub> O	12%
CO <sub>2</sub>	7.5%
Base gas	N <sub>2</sub>

Ambient temperature 200 °C

8. Controlling unit for NAP-78A

Sensors would work properly just by connecting to a control unit assembled in boilers because each sensors are equipped with a matched fixed resistor for temperature compensation and a matched V/R for zero point output calibration. As users do not need to look after for the individual differences of sensors, no complicated sensor selection is required. The control unit (on the boiler side) should have the following functions.

- \* A function to provide a sensor supply voltage in the range of 1.9 - 2.1 V.
- \* A self-diagnostic function for sensor filament broken and short-circuit.
- \* A function to memorize an initial reading in clean air as the zero \* point.
- \* The zero point of sensor is preset at +10 +/- 2 mV, but the preset level can be altered upon user's request.
- \* A function to carry out the heat cleaning described in " 5.Rating " when a boiler is switched-on.

With a controlling unit having the above functions, NAP-78A would work properly. For users' reference, a model circuit of such a controlling unit is shown below, but this does not include a function to monitor and control the combustion conditions depending on sensor signals. Combustion condition controlling systems should be designed by users for the most appropriate units to each boilers.



NEMOTO & CO., LTD

1-15-1, Kamiogi, Suginami-ku, Tokyo 167-0043, Japan  
 Tel. 81-3-3392-7181 Fax. 81-3-3392-7188  
 e-mail : intsales@nemoto.co.jp

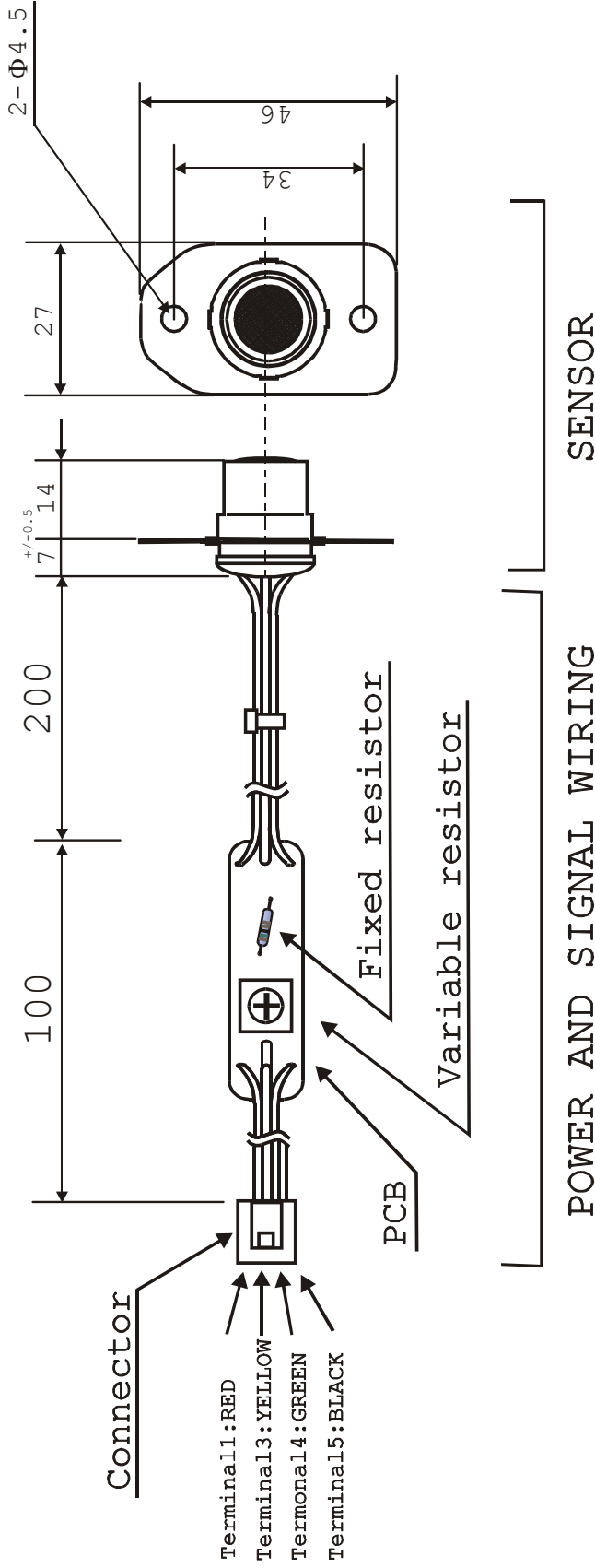

Power and signal wiring	Heat resistance 200 °C UL3533
Chip resistor for bridge circuit	510Ω +/-1%
Fixed resistor	+/-1%
Variable resistor	500Ω NIDEC COPAL ELECTRONICS CORP. FT-6
PCB	Outline dimensions : 37 X 10 UL94-0
Connector	Housings N-1020-9205 Receptacles 172032-M2 (NIPPON TANSHI)



Since 1941  
NEMOTO & CO.,LTD

1-15-1, Kamiogi, Suginami-ku, Tokyo 167-0043, Japan  
Tel. 81-3-3392-7181 Fax. 81-3-3392-7188  
e-mail : intsales@nemoto.co.jp

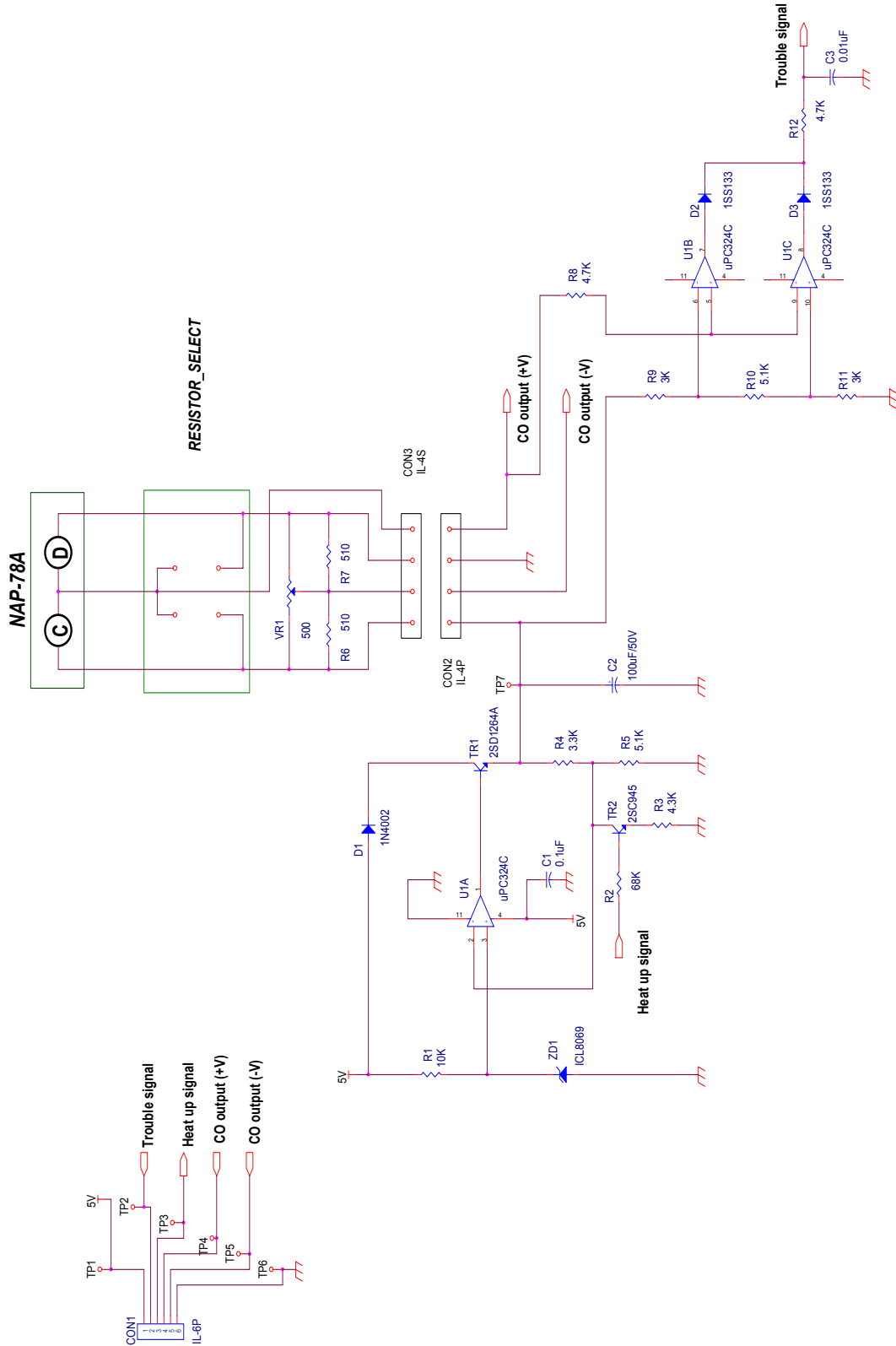

RE: Recommended circuit diagram for NAP-78A	
3K	Document Number
D	00AKK04V-002
DATE	1999/06/08
REV	1.1