



Nemoto Sensor Engineering Company Ltd

Nemoto (Europe) B.V.
World Trade Centre
Strawinskylaan 647
1077 XX Amsterdam
The Netherlands
Tel +31 20 670 3858
Fax +31 20 670 2709
www.nemoto.eu

Operating Characteristics and Handling Manual for the NAP-56A Explosive/Flammable Gas Sensor



The Nemoto NAP56A is a new, improved low cost catalytic flammable gas sensor. Closely related to the very popular NAP-55A sensor, the NAP-56A uses exactly the same sensing elements, but the enclosure in which they are mounted employs a nickel plated brass mounting cap and a phenolic resin header, instead of the Nylon 66 material used in the NAP-55A. As a result, the sensor exhibits an increased sensitivity output and an increase in useful temperature range, whilst being very slightly larger in dimensions, compared to the NAP-55A. The widened temperature range of the NAP-56A makes it particularly suitable for applications such as recreational vehicles, caravans and marine applications where a wide temperature range is required.

Nemoto has a policy of continuous development and improvement of its products. As such the specification for the device outlined in this document may be changed without notice.

NAP-56A Handling Manual, July 2010



Contents

Principles of Operation.....	3
General Specifications.....	4
Outline Drawing, Dimensions and Materials of Construction.....	5
Performance Measurements.....	6
Gas Sensitivity.....	6
Temperature Dependence.....	7
Humidity Dependence.....	8
Long Term Stability.....	9
Notes on Sensor Testing.....	10

Note that the Performance measurements expressed in this document should be considered as typical characteristics for guidance only, and not as specifications which are guaranteed, apart from those in the sections "General Specifications" and "Dimensions" (Pages 4 and 5). It is the instrument designer's responsibility to ensure that the sensor is suitable for any given application.

Principles of Operation:

Catalytic combustion has been the most widely used method of detecting flammable gases in Industry since the invention of the catalysed pelletized resistor (or "Pellistor") over 40 years ago.

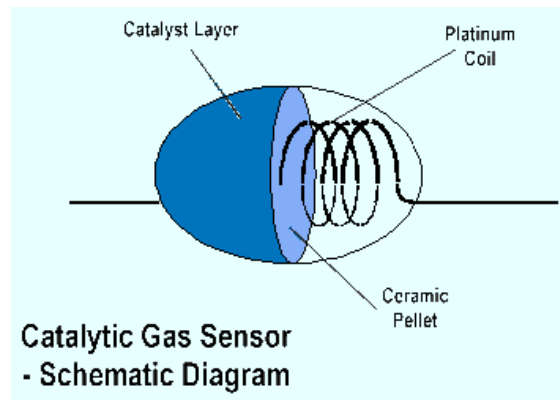

A Pellistor consists of a very fine coil of platinum wire, embedded within a ceramic pellet. On the surface of the pellet is a layer of a high surface area noble metal, which, when hot, acts as a catalyst to promote exothermic oxidation of flammable gases. In operation, the pellet and so the catalyst layer is heated by passing a current through the underlying coil. In the presence of a flammable gas or vapour, the hot catalyst allows oxidation to occur in a similar chemical reaction to combustion. Just as in combustion, the reaction releases heat, which causes the temperature of the catalyst together with its underlying pellet and coil to rise. This rise in temperature results in a change in the electrical resistance of the coil, and it is this change in electrical resistance which constitutes the signal from the sensor.

Pellistors are always manufactured in pairs, the active catalysed element being supplied with an electrically matched element which contains no catalyst and is treated to ensure no flammable gas will oxidise on its surface. This "compensator" element is used as a reference resistance to which the sensor's signal is compared, to remove the effects of environmental factors other than the presence of a flammable gas.

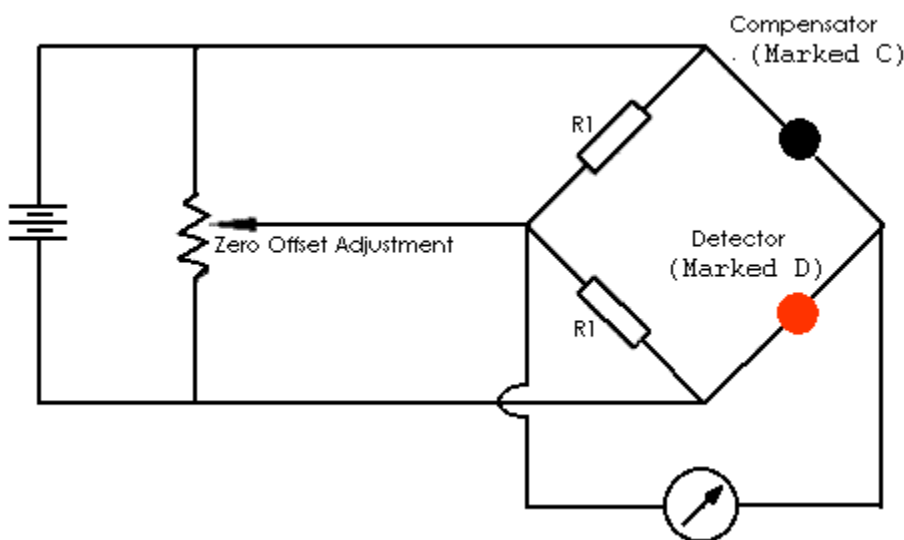

Pellistor Drive/Measurement Circuit: A simple Wheatstone Bridge to compare the resistance of two hot elements



The advantage of using this technique when detecting flammable gases for safety purposes is that it measures flammability directly.

Nemoto provides matched pair Pellistors conveniently mounted in a variety of enclosures for different applications. Some of these options contain the detector and compensator elements in separate enclosures (the NP range for Industrial applications). In the case of the NAP-56A, both elements are contained within a plastic enclosure for ease of use and low cost.

Catalytic pellistor type gas sensors have many advantages compared with semiconductor type gas sensors

- ❖ Linear output in proportion to gas concentration
- ❖ Greater Stability
- ❖ Higher reproducibility
- ❖ Gas specific - will only respond to flammable gases
- ❖ Unaffected by humidity
- ❖ Stable output for long periods
- ❖ More resistant to shocks and vibrations.

General Specifications:

Operating Specifications:	
Detected Gases	Flammable Gases (All specifications are based on the detection of Methane/Natural Gas)
Standard Concentration Range	0 – 2.5% Methane in Air (0-50% LEL)
Recommended Bridge Voltage	2.5V +/- 0.25V
Current Consumption (at Recommended Bridge Voltage)	170mA +/- 10mA
Bridge zero offset	0 +/- 35mV
Output Sensitivity	15-23 mV for 3000ppm CH₄
Linearity	Effectively Linear to 50% LEL
Response Time (Measured as T90)	<10 secs
Accuracy (Measured as Repeatability)	± 0.5mV for Zero ± 0.5mV for Gas Sensitivity
Long Term Stability Drift	Zero: Less than +/- 2mV per year Sensitivity: Less than +/- 2mV per Month
Expected Lifetime in the field	Over 5 Years. (In an appropriate Residential or Light commercial application)
Environmental Specifications:	
Temperature Range	-40°C to +70°C
Standard constant Humidity Range	15 to 90%RH
Standard Constant Pressure Range	1atm ± 10%
Recommended storage Temperature Range	0 to 20 degree C
Recommended Maximum Storage Time	6 months
Mechanical Data	
Enclosure Material	Nickel Plated Brass
Connector Pin Material	Nickel
Header (Base) Material	Phenolic Resin
Protective Mesh Material	316 SS

Dimensions, Structure and Materials of Construction

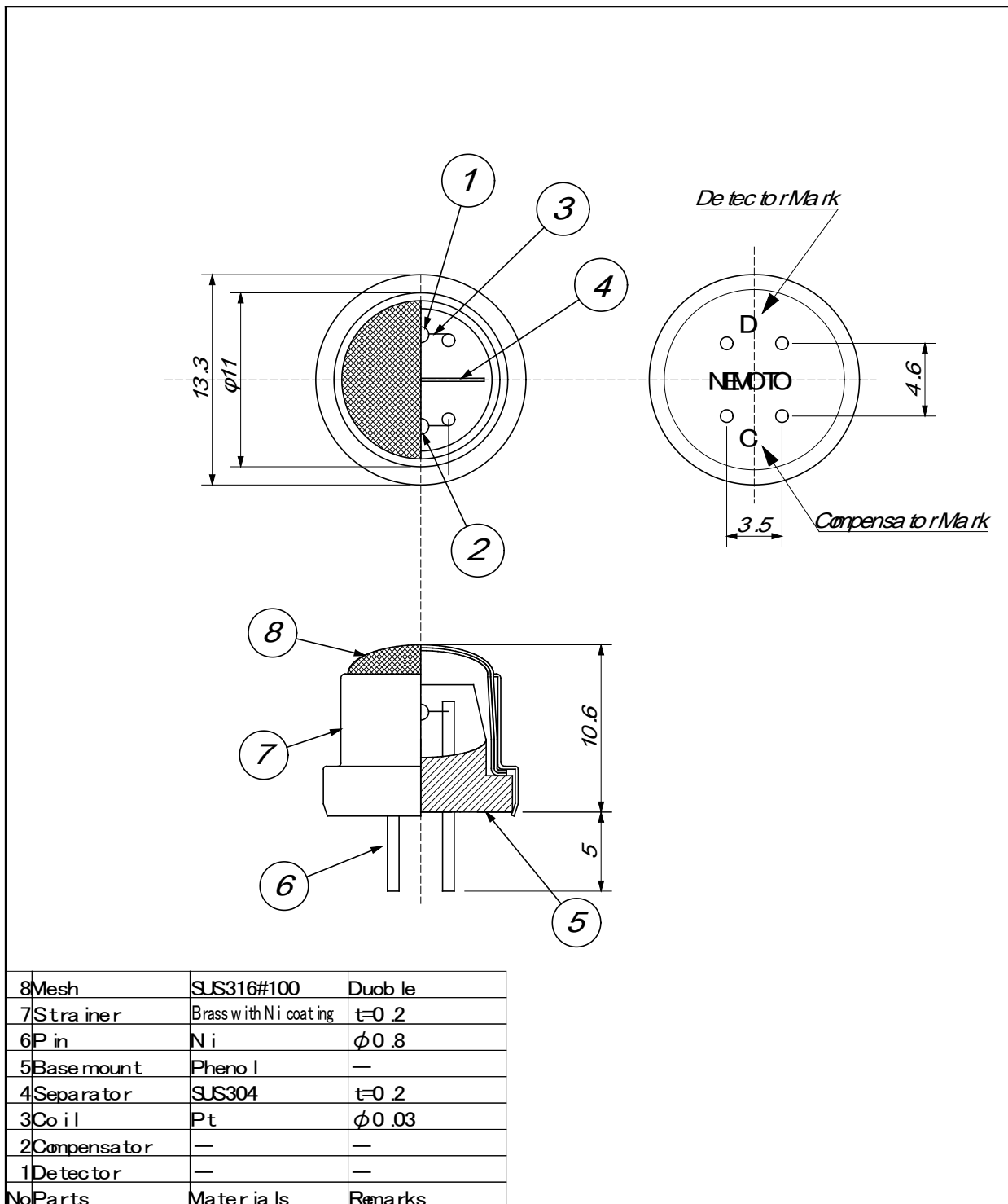



Performance Measurements

The NAP-56A sensor is derived largely from the very popular NAP-55A sensor, the only difference being in the enclosure, which is slightly larger and made from different materials to result in a device which is tolerant to a wider temperature range. The typical performance of the sensor can hence be largely taken as being very similar to the NAP-55A in most respects.

The chief performance difference between the two sensors is that the signal output of the NAP-56A is slightly higher than for the NAP-55A, and so the performance details given here are those which is related to this difference.

Response characteristics, resistance to catalyst poisons, wind / flow rate effects and lifetime considerations can be considered to be similar to those given in the operating manual for the NAP-55A.

Gas sensitivity

The graph below shows the typical sensitivity characteristics for methane, hydrogen, Isobutane and Ethanol

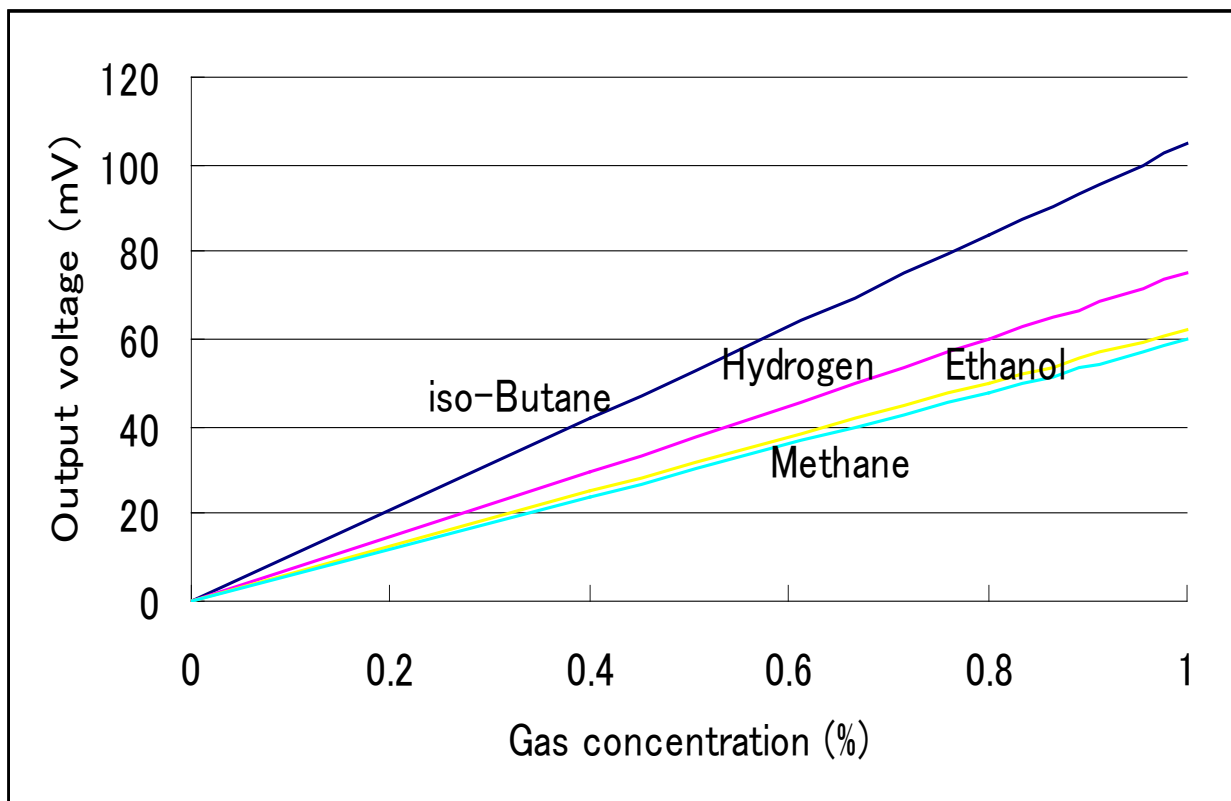

For other flammable gases, Nemoto can advise on the anticipated sensitivity of the sensor alone, but since the relative sensitivities to various gases is also dependent on the mounting arrangement within an instrument, it is always recommended that the instrument maker determines the response of the sensor to the target gas by experiment using the final product design wherever possible.

Temperature Dependence

Typical Zero Offset Drift with Temperature

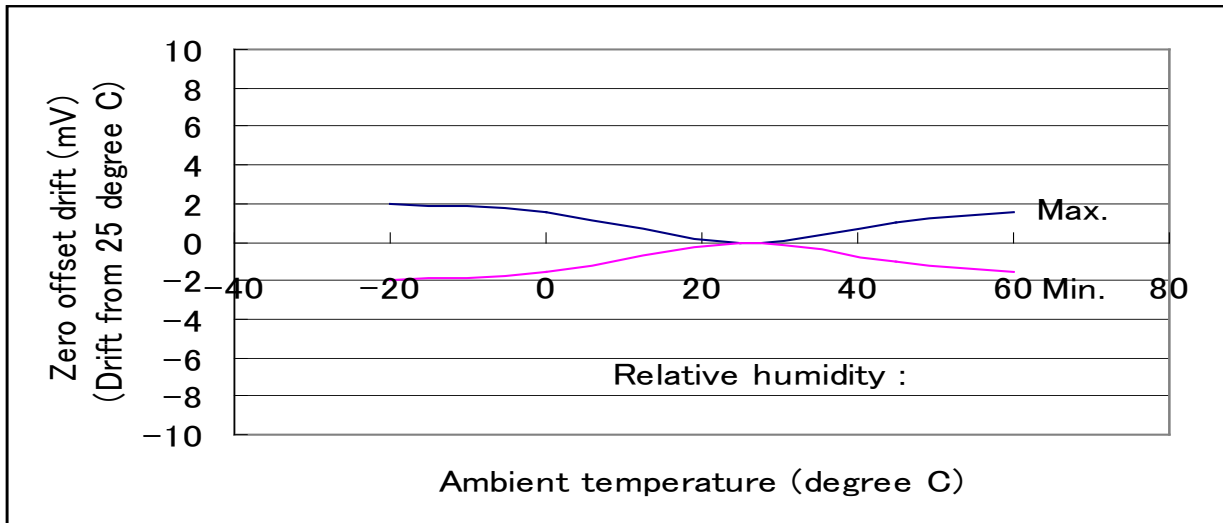

Typical Gas Sensitivity Drift with Temperature

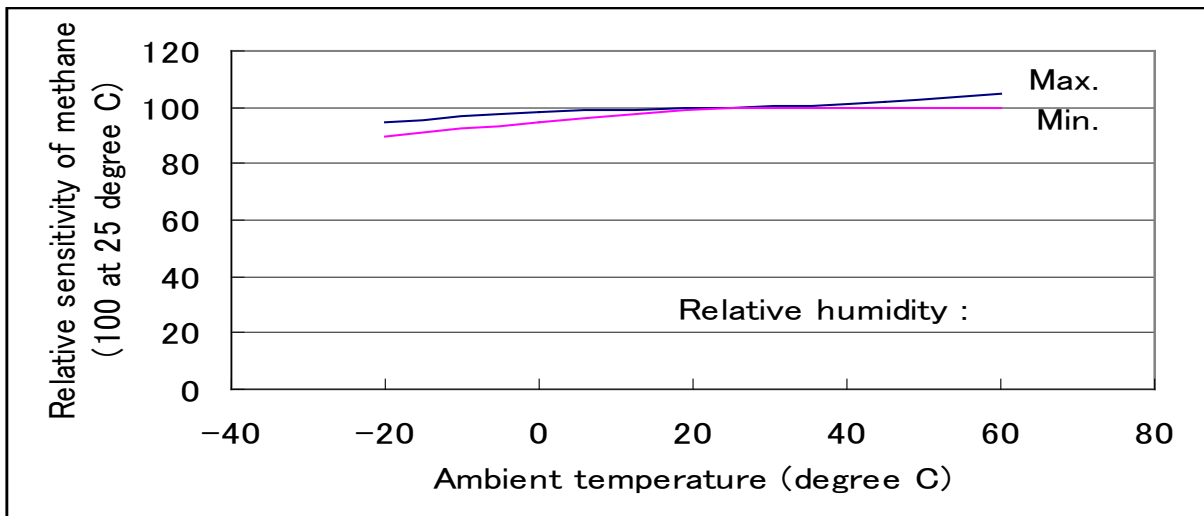

Humidity Dependence

Typical Zero Offset Drift with Humidity

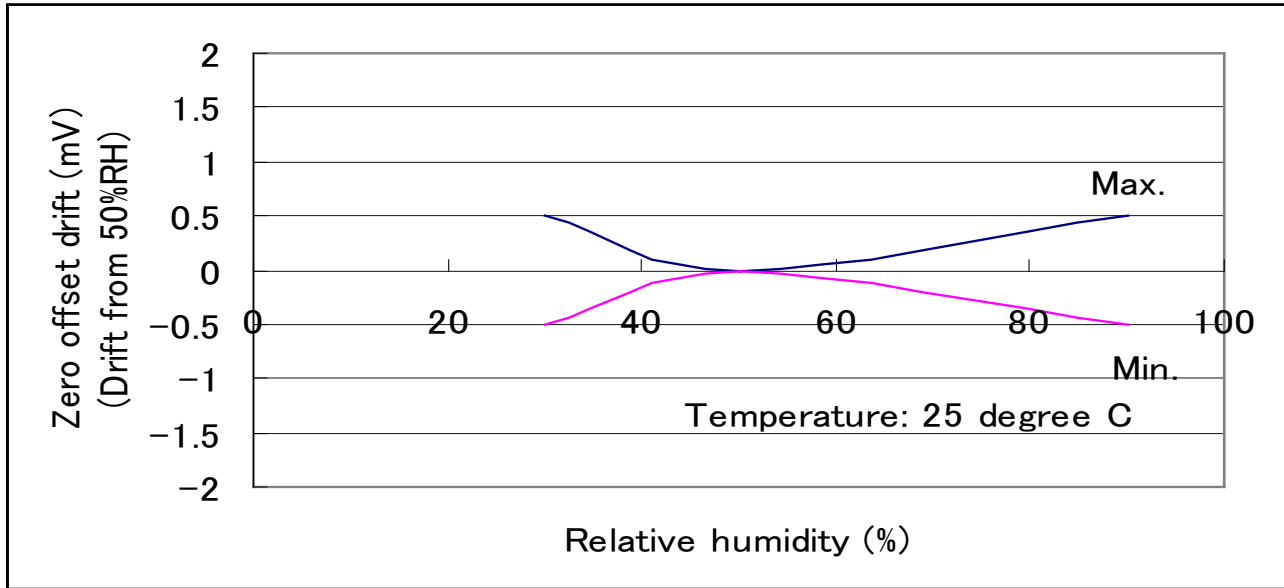

Typical Gas Sensitivity Drift with Humidity

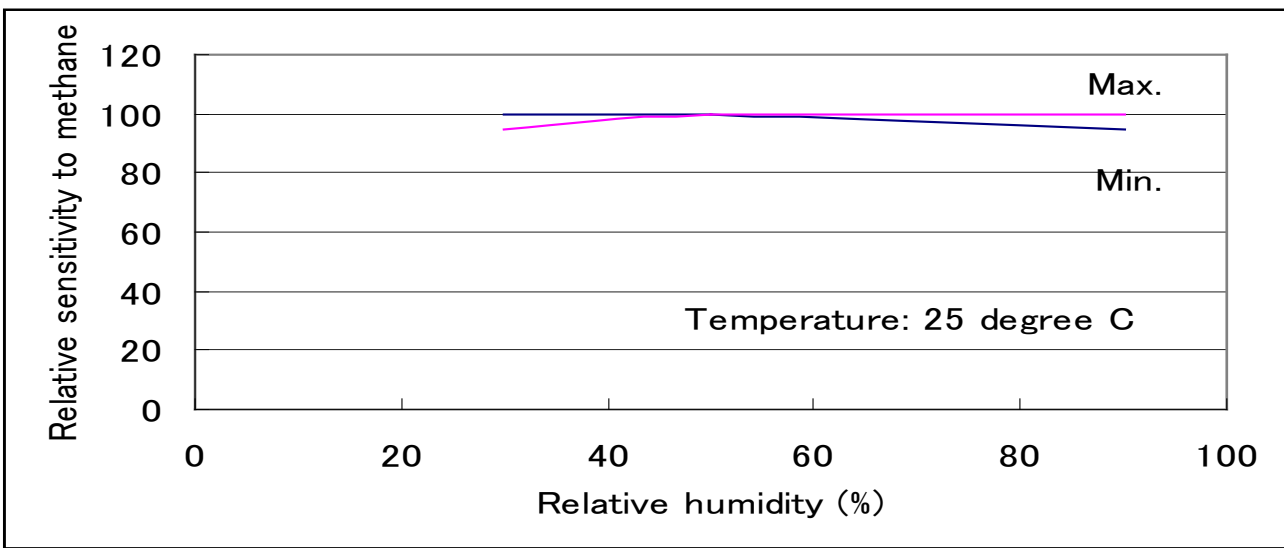

Long Term Stability

Typical Long Term Zero offset Drift

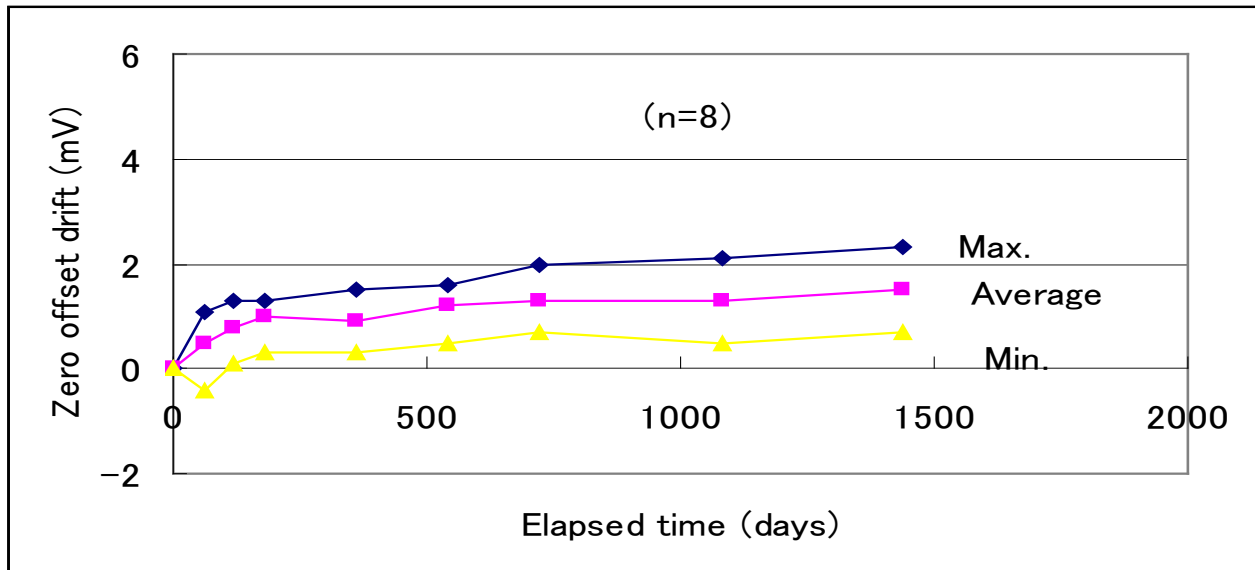

Typical Long Term Gas sensitivity Drift

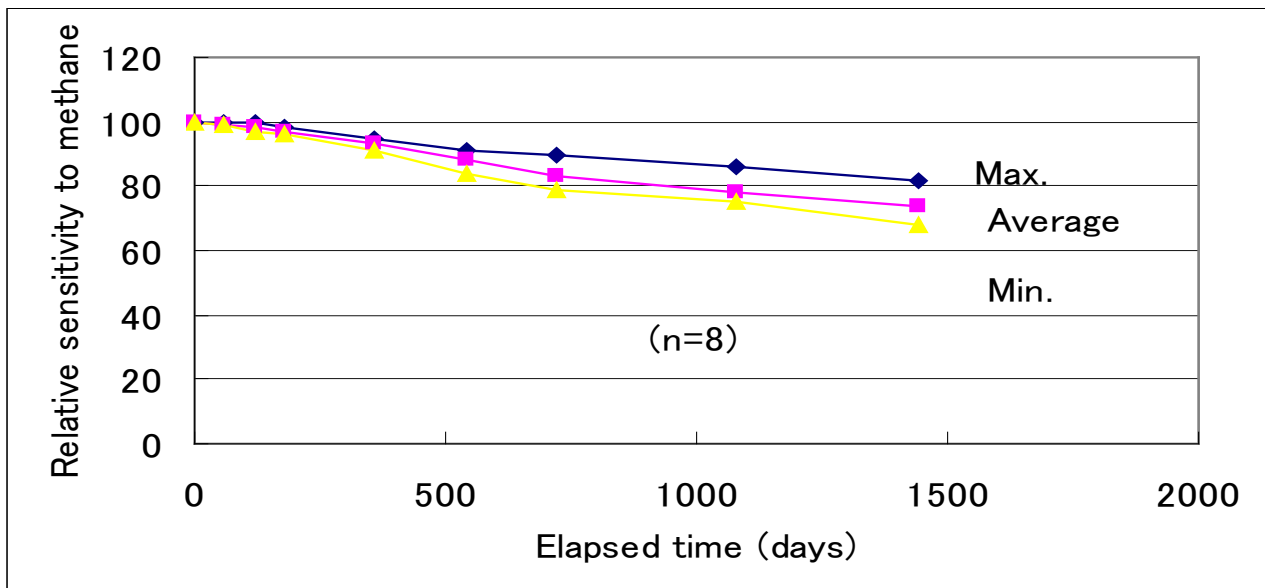

Notes on sensor testing

All Nemoto specifications are based on testing within a gas filled chamber. Testing the sensor using a flow-through system will yield similar, but not identical, results. The Nemoto test set up is illustrated below:

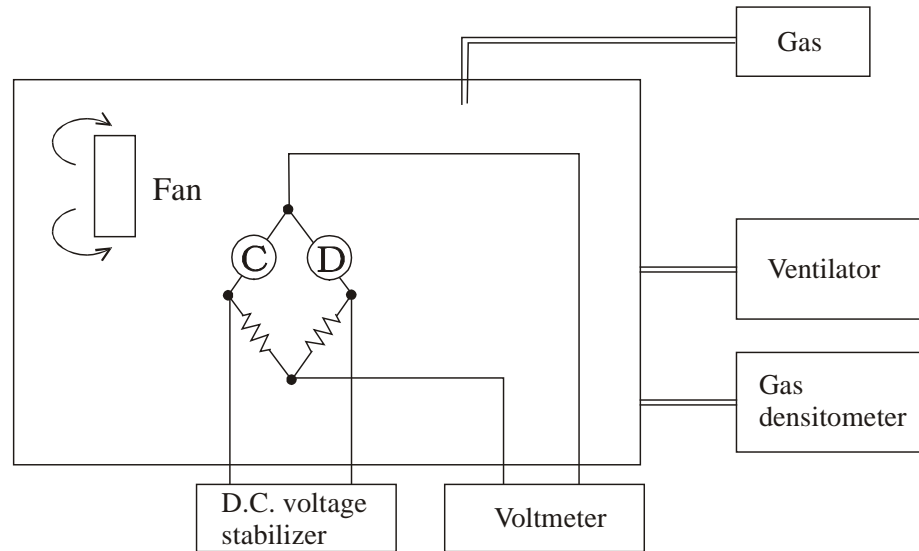

The test chamber should be constructed of glass, or another material known not to absorb gases.

In Nemoto's test regime, test gases are introduced into the chamber by injection, following careful calculation of the amount of gas required to generate the required concentration within the chamber. This may also be accomplished by purging the chamber using gas from a test gas cylinder, provided the flow rate used is not high enough to cause turbulence in the chamber.

The gas inside the chamber should be gently agitated by a slow moving fan, to ensure that concentration gradients do not develop during testing, either by stratification layers forming in the chamber, or by the consumption of the gas by the sensors themselves.