

NAP-66A Catalytic Gas Sensor for Propane / Butane / LPG

The NAP-66A Gas Sensor is a low-cost Catalytic Flammable Gas Sensor designed for the detection and measurement of Propane, Butane, and LPG vapours in the range 0-50% LEL. Developed primarily for use in Residential Gas Detectors, the NAP-66A has also been found to be useful in a wide variety of applications where reliable detection of gas or fuel leaks and other gas hazards is required at low cost.



The NAP-66A uses the superior catalytic “pellistor” detection principle often used in high quality Industrial Gas Detectors. It hence has many benefits over other low cost gas sensor types:

- **Monitors flammability directly**
- **Unaffected by humidity**
- **Very low long term drift**
- **Excellent resistance to catalytic poisons**
- **Single header design for ease of use**
- **Superb temperature stability**
- **Resistant to shocks and vibration**
- **Linear output to 50% LEL**

Specifications NAP-66A:

Detectable gas:	Propane/Butane/LPG
Detection range:	0-50% LEL (0-2.5% V/V)
Bridge Voltage	2.0V +/- 0.2V
Bridge Current	180mA +/- 10mV
Gas Signal*:	Typically 16mV @2000ppm C ₄ H ₁₀
Bridge zero offset*:	0 +/- 35mV

*in Nemoto's recommended bridge circuit

Repeatability:	
Zero:	+/- 0.5mV
Signal:	+/- 0.5mV
Expected lifetime:	5 years

Long Term Drift: Zero:	<+/- 5mV/month
Span:	<+/- 2%/month
Linearity:	Effectively Linear to 50% LEL
Response time(T ₉₀):	<10 seconds

Note: In practice the response time of a gas sensor is very much dependent on the mounting arrangement within an instrument.

Environmental Conditions:

Operating temperature:	-10°C to +50°C
Humidity range:	0-95% RH
Pressure:	0.9 – 1.1 atm
Storage Temperature:	-20°C to +50°C
Recommended Storage Time:	6 months

More detailed information, covering all aspects of performance, including long term stability, repeatability, environmental tolerances to humidity, temperature, wind, shock, cross sensitivity to other gases, recommended circuitry, handling requirements and an explanation of the operating principles of the NAP-66A, please consult the Handling Manual for the device, available on request.

NAP-66A datasheet April 2008

Nemoto has a policy of continuous development and improvement of its products. As such the specification for the device outlined in the data sheet may be changed without notice.

Nemoto (Europe) B.V.
 Strawinskyiaan 647,1077 XX Amsterdam, Netherlands
 TEL: +31 20 670 3858
 FAX: +31 20 670 2709
 URL: <http://www.nemoto.co.jp>

Dimensions, Materials and Recommended Circuit

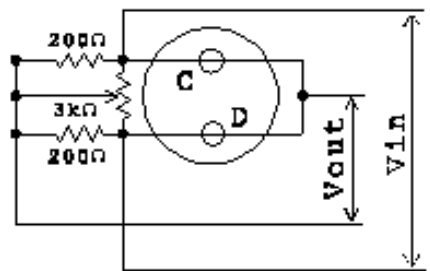
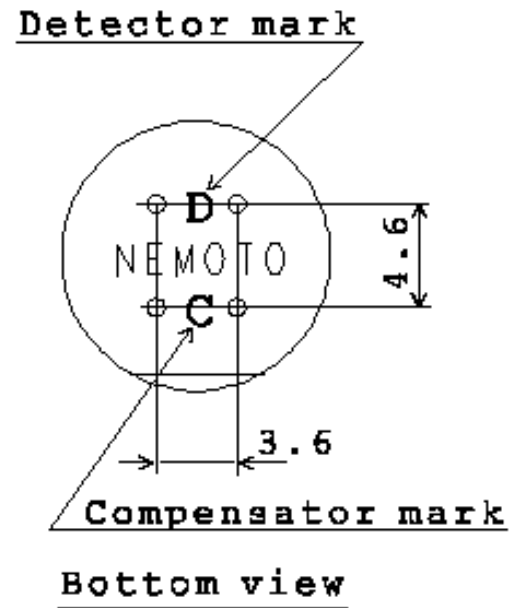
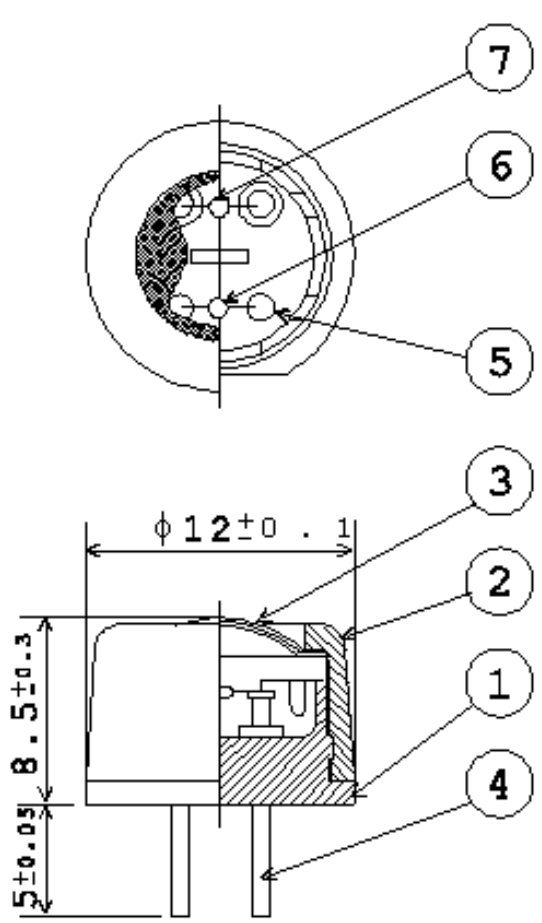

Measuring circuit

7	Detector	_____	NEMOTO & CO., LTD.
6	Compensator	_____	NEMOTO & CO., LTD.
5	Coil	Pt	$\phi 30 \mu\text{m}$
4	Pin	Pure Ni	$\phi 0.8$
3	Strainer	809316 $\phi 100 \text{ mesh}$	Double layered
2	Cap	66Nylon	20% Glass
1	Base mount	66Nylon	20% Glass
No.	PARTS	MATERIALS	REMARKS

	APPROVED	CHECKED	DESIGNED	DRAWN	MATERIAL	Q. TY	SCALE
					DATE	DRG. NO.	
	TITLE				DEC, 25, 1993	G-01-04-143	
NAP-66A					NEMOTO & CO., LTD.		