



# NEMOTO Sensor Engineering Co.Ltd

## NAP-67A Catalytic Gas Sensor for Propane / Butane / LPG

The Nemoto NAP-67A is a new, improved low cost catalytic flammable gas sensor. Closely related to the very popular NAP-66A sensor, the NAP-67A uses exactly the same sensing elements, but the enclosure in which they are mounted employs a nickel plated brass mounting cap and a phenolic resin header, instead of the Nylon 66 material used in the NAP-66A. As a result, the sensor exhibits an increased sensitivity output and an increase in useful temperature range, whilst being very slightly larger in dimensions, compared to the NAP-66A.



The widened temperature range of the NAP-67A makes it particularly suitable for applications such as recreational vehicles, caravans and marine applications where a wide temperature range is required.

- **Monitors flammability directly**
- **Wide Temperature Range**
- **Very low long term drift**
- **Excellent resistance to catalytic poisons**
- **Single header design for ease of use**
- **Superb temperature stability**
- **Resistant to shocks and vibration**
- **Linear output to 50% LEL**

### Specifications NAP-67A:

Detectable gas: Propane/Butane/LPG

Note: The NAP-67A is not recommended for the measurement or detection of Methane.

Detection range: 0-50% LEL  
Bridge Voltage 2.0V +/- 0.2V  
Bridge Current 160mA +/- 10mV  
Gas Signal\*: Typically 20mV @2000ppm C<sub>4</sub>H<sub>10</sub>  
Bridge zero offset\*: 0 +/- 35mV

\*in Nemoto's recommended bridge circuit

Repeatability:  
Zero: +/- 0.5mV  
Signal: +/- 0.5mV

Long Term Drift: Zero: <+/- 5mV/month

Span: <+/- 2%/month

Linearity: Effectively Linear to 50% LEL

Response time(T<sub>90</sub>): <10 seconds

Note: In practice the response time of a gas sensor is very much dependent on the mounting arrangement within an instrument.

### Environmental Conditions:

Operating temperature: -40°C to +70°C

Humidity range: 0-95% RH

Pressure: 0.9 – 1.1 atm

Storage Temperature: -20°C to +50°C

Recommended Storage Time: 6 months

NAP-67A datasheet July 2010

Nemoto has a policy of continuous development and improvement of its products. As such the specification for the device outlined in the data sheet may be changed without notice.

Nemoto (Europe) B.V.  
Strawinskylaan 647,1077 XX Amsterdam, Netherlands  
TEL: +31 20 670 3858  
FAX: +31 20 670 2709  
URL: <http://www.nemoto.co.jp>

# Dimensions, Materials and Recommended Circuit

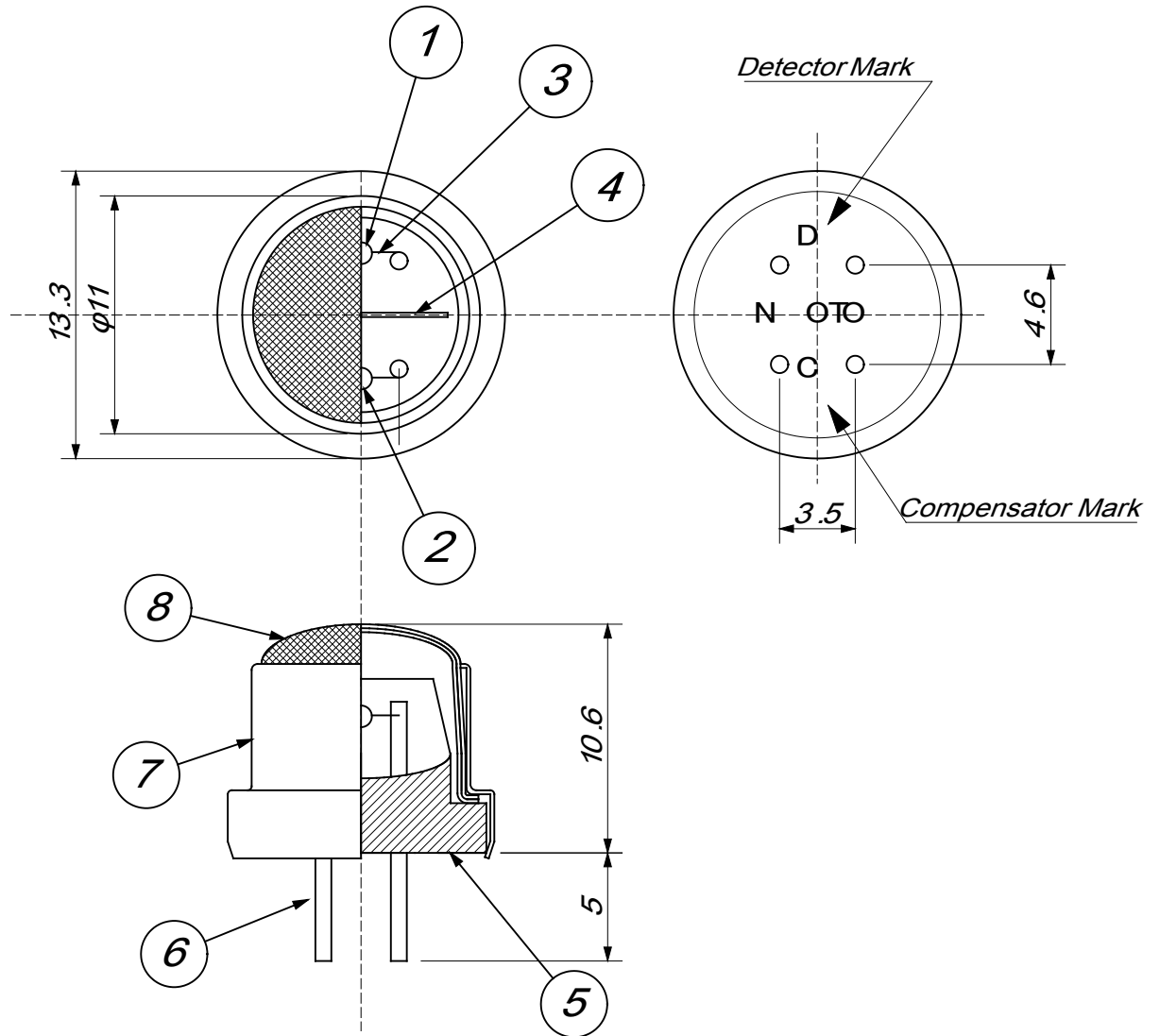

Label	Part	Material	Comments
1	Detector	N/A	N/A
2	Compensator	N/A	N/A
3	Coil	Platinum	$\varnothing = 0.03$
4	Separator	304 SS	T = 0.2
5	Base Mount (Header)	Phenolic Resin	
6	Connecting Pin	Nickel	$\varnothing = 0.8$
7	Protective Can	Nickel Plated Brass	T = 0.2
8	Mesh	316 SS	Double