

# ***SPECIFICATIONS***

(Humidity sensor NHS-25)

**Nemoto & Co.,Ltd.**

4-10-9 Takaido-Higashi Suginami-ku Tokyo

168-0072 Japan

TEL 81-03-3333-7341

FAX 81-03-3333-7344

## 1.Application

This specifications is to be applied to Nemoto humidity NHS-25

## 2.Ratings

Supply voltage	Less than AC1.5V AC1.0V is recommended.
Wave shape	Sine or square wave shape.
Frequency	500 – 2,000Hz 1kHz is recommended.
Power consumption	Less than 2mW (when 1.0V is supplied.)
Humidity range	20 – 100%RH(in operation) 10 – 95%RH(in storage)
Temperature range	0 – 60°C (in operation) -20 – 70°C (in storage)

## 3.Sensitivity Characteristics

Guaranteed impedance	20k $\Omega$ at 25°C, 60 $\pm$ 5%RH
Humidity characteristics	See attached figure 1.
Typical humidity sensor Characteristics	See attached table 1.
Response characteristics	See attached figure 2.
Hysteresis	See attached figure 3.

#### 4.Appearance and dimensions

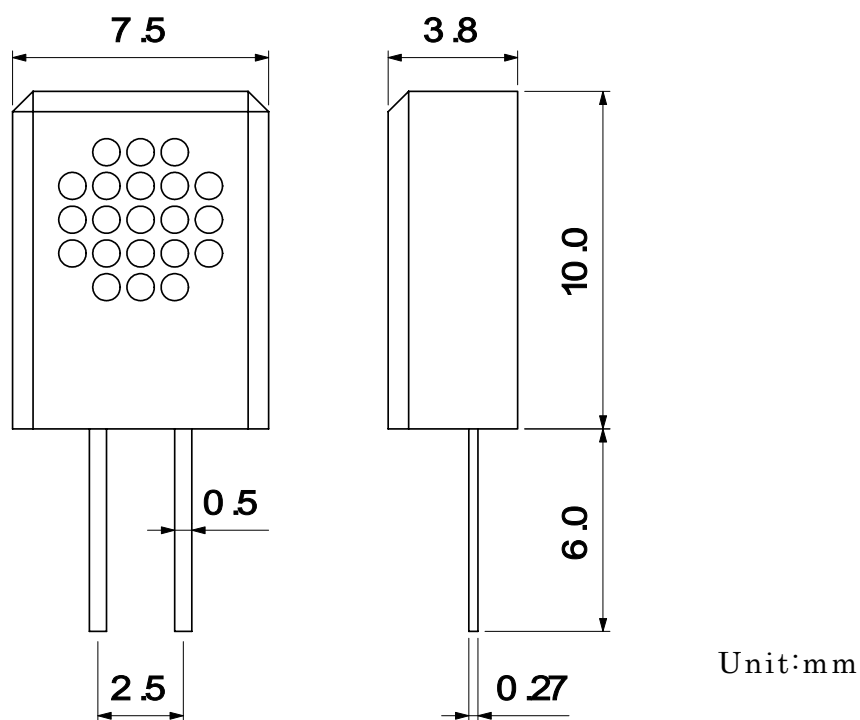

Case material	ABS resin
Case color	Light blue
Lead frame	Phosphor bronze(Sn plated)
Weight	0 . 3 3 g (approx.)

#### 5.Mechanical durability

Drop test (Dropped onto wooden plate from a height of 1m, 3 times)	Passed
Vibration test (Amplitude of 5mm, X, Y, Z directions, 10Hz for 20 min.)	Passed
Tensile strength of lead wire (Pulled with 1kg load for 10 sec.)	Passed
Lead wire bending test (lead wire was bended to 90 degrees with 250g load, and bended again to opposite direction.)	Passed

## 6. Reliability 1 (Temperature and humidity test)

Sensors were tested/stored in the conditions described below respectively, and the humidity characteristics at 25°C, 60%RH before test and after test were inspected, and described in the following table.

Test conditions		Variation
1	Sensors are stored in high temperature(80°C) for 1,000 hrs.	< ± 5%RH
2	Sensors are stored in low temperature(-20°C) for 1,000 hrs.	< ± 5%RH
3	Sensors are stored in high temperature and high humidity (50°C,90%RH) for 1,000 hrs.	< ± 5%RH
4	Sensors are stored in low humidity (25°C, less than 15%RH) for 1,000 hrs.	< ± 5%RH
5	Sensors are energized in high temperature(80°C) for 1,000 hrs. Supply voltage is AC1.0V, 1kHz.	< ± 5%RH
6	Sensors are energized in high temperature and high humidity (50°C,90%RH) for 1,000 hrs. Supply voltage is AC1.0V, 1kHz.	< ± 5%RH
7	200 cycles of dewing condition for 10 minutes – drying condition for 10 minutes.	< ± 5%RH

## 7. Reliability 2 (Organic solvent vapor, corrosive gases)

Test conditions		Variation
1	Methanol (Conc. 1%, 100 hrs.)	< ± 5%RH
2	Ethanol (Conc. 1%, 100 hrs.)	< ± 5%RH
3	Ammonia (Conc. 1%, 100 hrs.)	< ± 5%RH
4	Acetic acid (Conc. 1%, 100 hrs.)	< ± 5%RH
5	Mixed solvents (Benzene 3 : Toluene 3 : Xylene 4, saturated 100 hrs.)	< ± 5%RH
6	H <sub>2</sub> S (Conc. 200ppm, 20 hrs.)	< ± 5%RH
7	Acetone (Conc. 1%, 100 hrs.)	< ± 5%RH
8	SO <sub>2</sub> (Conc. 200ppm, 20 hrs.)	< ± 5%RH
9	Cigarette Smoke (2 pcs. / 18 litter, 25 hrs × 2 times)	< ± 5%RH

## 8. Remarks

- \* Keep rated conditions.
- \* Do not disassemble the sensor element.
- \* Do not supply direct current to sensor.
- \* Do not spray water, any organic solvents, oils and etc. directly to element.
- \* Prevent sensor from corrosive gases and high concentration of organic solvent vapor.
- \* Sensor is durable enough under high temperature / humidity or dew condensation conditions, but storage for an exceedingly long time under too severe conditions may cause improper functions.
- \* Polymeric humidity sensing layer may be damaged at 100°C or more. Refrain from using re-flow soldering systems.

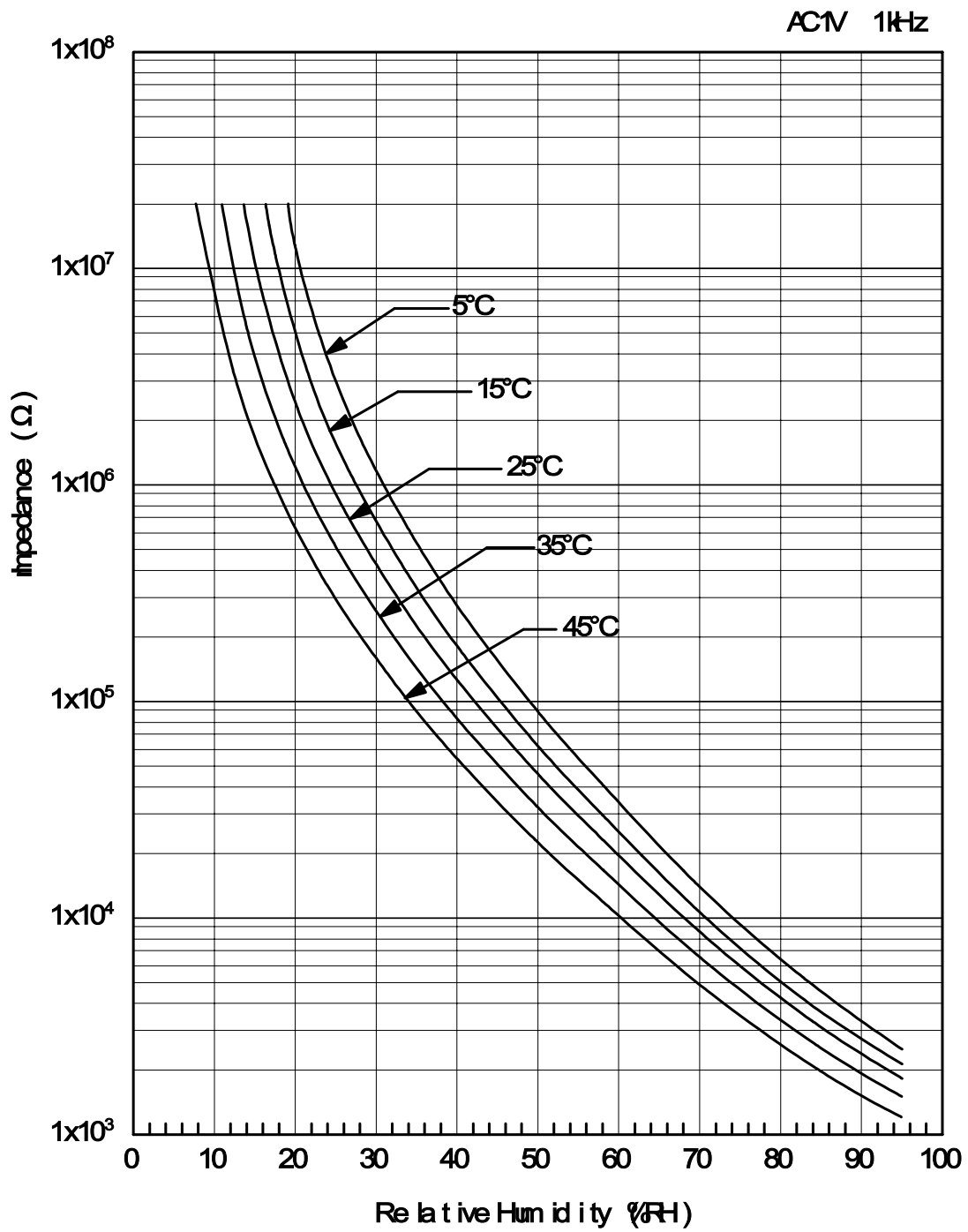

Fig. 1 : Sensitivity Characteristics

AC :1V 1kHz

UNIT :k $\Omega$ 

	5°C	10°C	15°C	20°C	25°C	30°C	35°C	40°C	45°C	50°C
20% RH	13400	8117	5070	3460	2470	1770	1280	869	635	458
25% RH	3000	2170	1650	1250	897	683	519	392	296	229
30% RH	1220	880	677	540	430	337	266	207	167	129
35% RH	551	423	335	276	228	184	152	119	88.8	69.7
40% RH	280	228	186	160	134	104	83.4	67.4	54.5	43.2
45% RH	164	135	106	87.4	74.9	62.1	51.1	42.1	35.4	27.9
50% RH	88.7	74.4	62.3	53.6	46.2	38.7	32.5	27.3	22.8	18.7
55% RH	54.8	46.1	38.9	34.1	29.6	25.0	21.7	18.6	15.9	13.1
60% RH	34.3	29.2	25.5	22.5	19.7	17.5	15.2	12.9	10.4	8.48
65% RH	22.0	19.1	17.0	15.3	13.7	11.6	9.55	8.26	6.97	5.92
70% RH	14.9	12.9	10.9	9.53	8.51	7.49	6.79	5.74	4.90	4.16
75% RH	9.25	8.21	7.20	6.57	6.00	5.30	4.66	4.06	3.54	2.99
80% RH	6.44	5.73	5.07	4.66	4.27	3.81	3.39	2.96	2.64	2.28
85% RH	4.58	4.09	3.69	3.40	3.12	2.83	2.56	2.28	1.98	1.77
90% RH	3.35	3.02	2.79	2.59	2.41	2.17	1.95	1.79	1.63	1.45
95% RH	2.53	2.34	2.15	1.98	1.87	1.73	1.59	1.47	1.34	1.21

**Tab. 1 : Typical humidity sensor Characteristics**

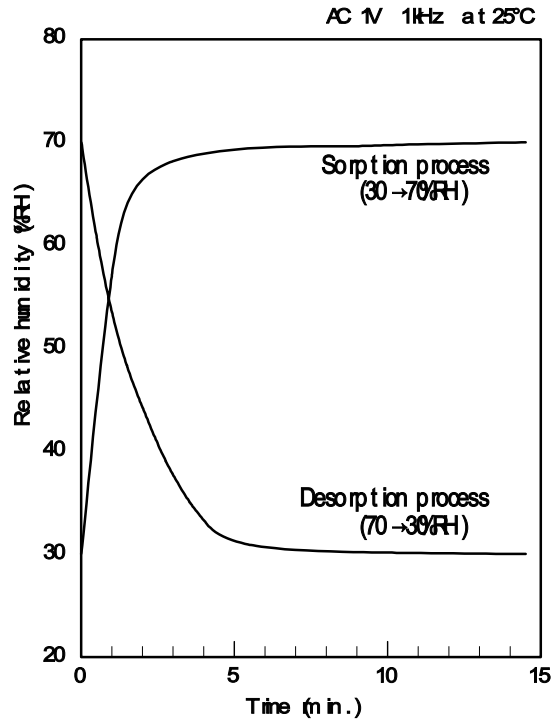

Fig. 2 : Response Characteristics

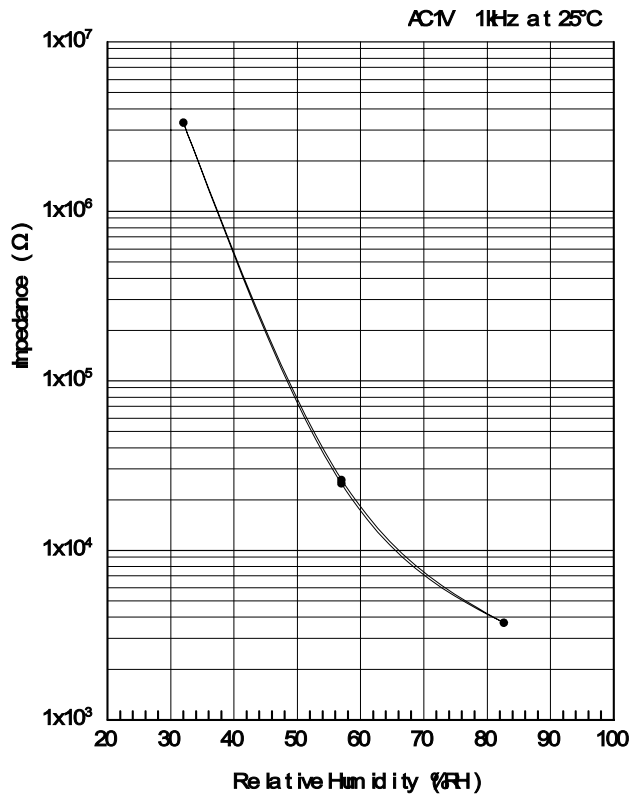

Fig. 3 : Hysteresis Loop

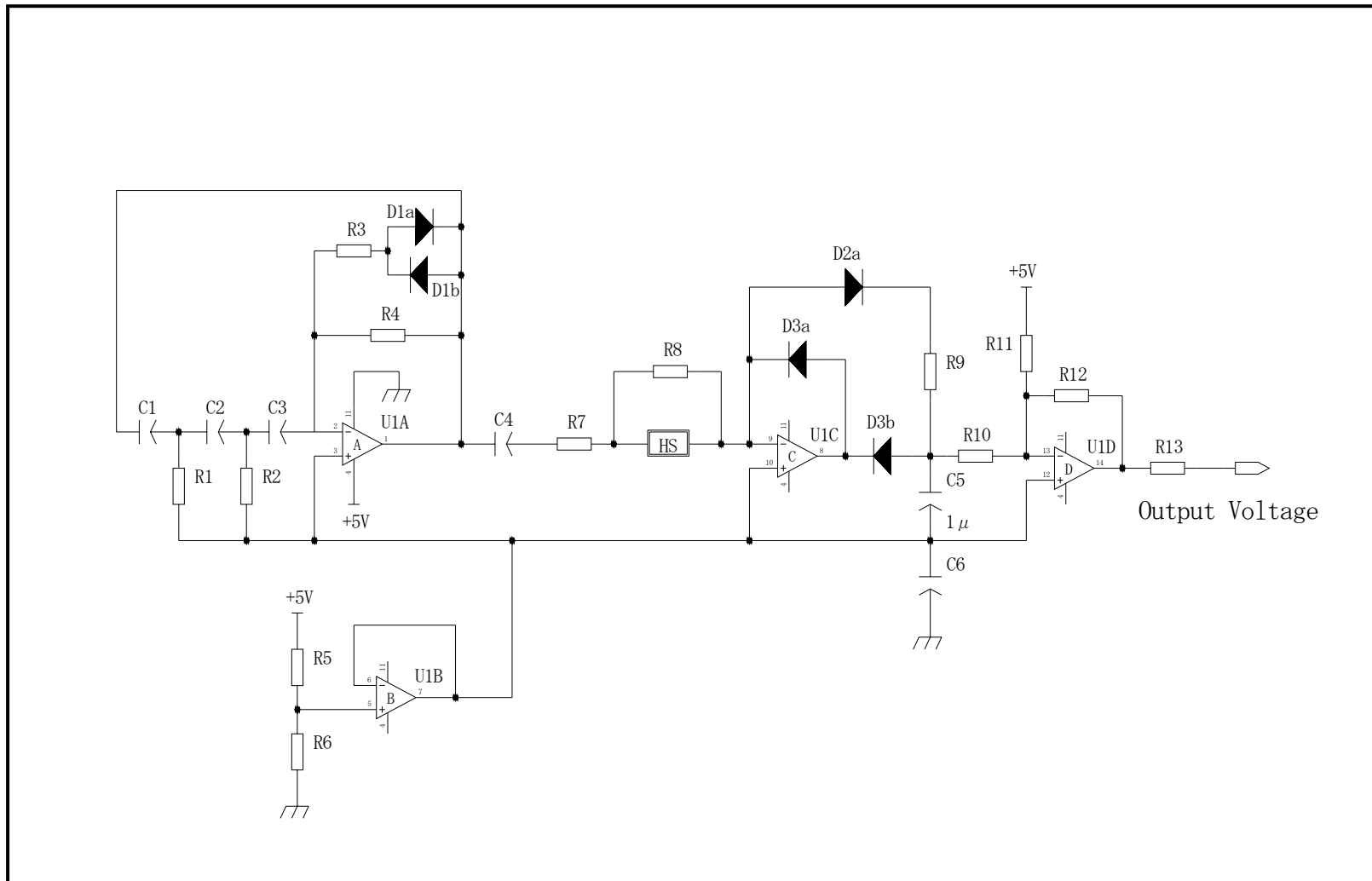

Fig 4. : Model circuit