



Nemoto & Co., Ltd
Sensor Division

4-10-9 Takaido-Higashi
Suginami-ku
Tokyo 168-0072,
Japan

www.nemoto.eu

Datasheet and Technical Manual for the NAP-78SU Catalytic gas sensor for the detection of incomplete combustion in boiler flues.

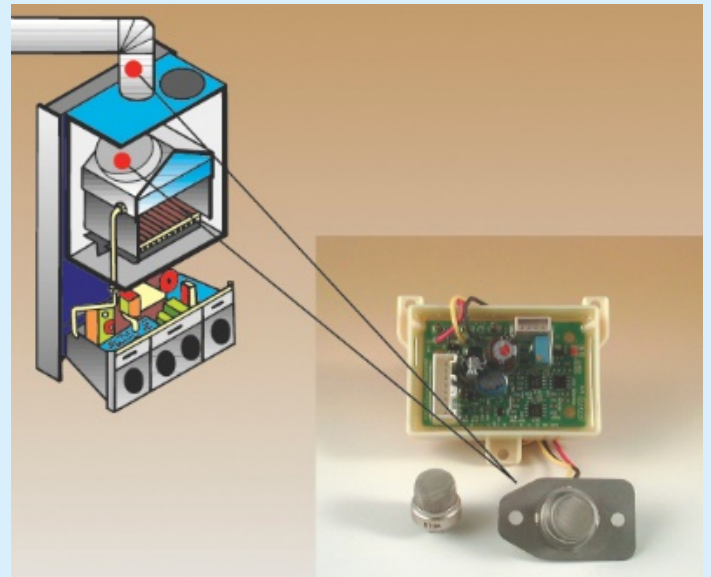
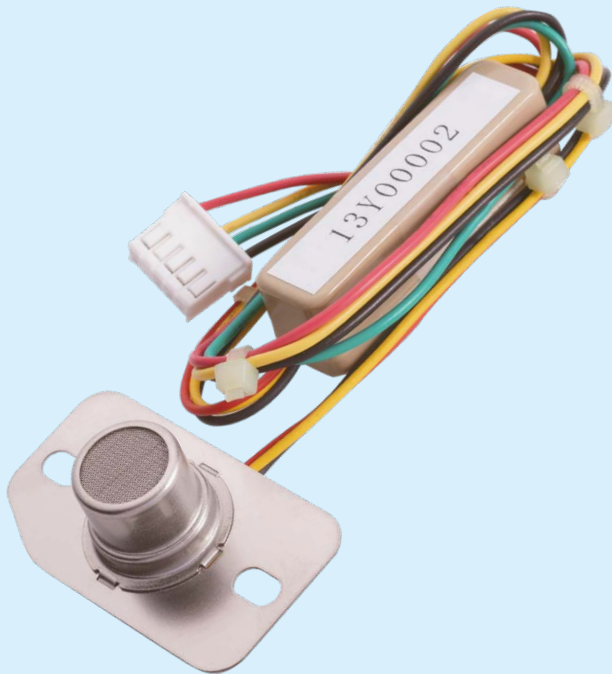

Nemoto has a policy of continuous development and improvement of its products. As such the specification for the device outlined in this document may be changed without notice.



Contents

| | |
|--|-------------------|
| Introduction and General Description..... | 3 |
| Principles of Operation..... | 3 |
| General Specifications..... | 5 |
| Outline Drawing and Dimensions..... | 6 |
| Sensor Structure..... | 7 |
| | |
| Performance Measurements..... | 8 |
| | |
| Gas Sensitivity and Linearity..... | 8 |
| Tolerance to Environmental Extremes and Durability..... | 8 |
| Temperature Dependence..... | 9 |
| Response to Hydrogen..... | 10 |
| Tolerance to Temperature Transients (Heat Shock)..... | 10 |
| Tolerance to Vibration..... | 10 |
| Initial Start-up time and optional Heat Cleaning Cycle..... | 10 |
| Long Term Stability, and periodic zero correction..... | 11 |
| | |
| Notes for Designers, Mounting of Sensors etc..... | 12 |
| Conceptual Schematic and Circuit Layout..... | 15 &16 |

Note that the performance measurements expressed in this document should be considered as typical characteristics for guidance only, and not as specifications which are guaranteed, apart from those in the sections "General Specifications" and "Dimensions" (Pages 5 and 6). It is the instrument designer's responsibility to ensure that the sensor is suitable for any given application.



Introduction and General Description

The NAP-78SU Gas Sensor from Nemoto is designed to continuously monitor the flue gases generated by gas or oil fired domestic hot water and central heating boilers in order to ensure the safety of the device and to limit the environmental impact of the boiler under fault conditions.

The sensor will detect the presence of high levels of carbon monoxide and/or hydrogen in the flue gases generated by the boiler. High levels of these gases in the flue during normal operation occur as a result of incomplete combustion, and hence indicate a faulty boiler which could pose a safety hazard within the dwelling in which it is fitted. The signal from the sensor can be used either to trigger an alarm, or to automatically turn the boiler off to ensure the safety and well-being of the people within the building.

The NAP-78SU is particularly useful as an indicator of a blocked or partially blocked flue, whether in the flues air intake or in its exhaust stage. Recent changes in standards relating to domestic water heating boilers, particularly the European Standard EN 483, have highlighted the necessity of accurately detecting this fault condition, and the NAP-78SU sensor accomplishes this with ease, ensuring compliance with this section of the standard.

The sensor uses the well proven Catalyzed Pelletized resistor (Pellistor) method, which is well established for the detection of Flammable gases in general ambient safety applications. In the case of the NAP-78SU the device is specially modified, including a special resistor matrix mounted in a separate box, to give stable and reliable performance when mounted inside a boiler flue working at high temperatures.

The NAP-78SU sensor is well proven as a reliable real time warning of unsafe combustion conditions within boilers, and all the specifications and performance data in this manual are designed with this primary application in mind. However, note that the NAP-78SU sensor can also be used in a wide variety of other applications where the monitoring of flammable / explosive gases is required within ductwork or flue stacks at high temperature.

Principles of Operation:

Catalytic combustion has been the most widely used method of detecting flammable gases in Industry since the invention of the catalysed pelletized resistor (or "Pellistor") over 40 years ago.

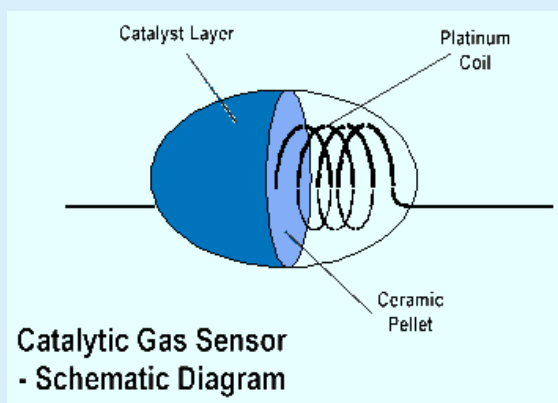

A pellistor consists of a very fine coil of platinum wire, embedded within a ceramic pellet. On the surface of the pellet is a layer of a high surface area noble metal, which, when hot, acts as a catalyst to promote exothermic oxidation of flammable gases. In operation, the pellet and so the catalyst layer is heated by passing a current through the underlying coil. In the presence of a flammable gas or vapour, the hot catalyst allows oxidation to occur in a similar chemical reaction to combustion. Just as in combustion, the reaction releases heat, which causes the temperature of the catalyst together with its underlying pellet and coil to rise. This rise in temperature results in a change in the electrical resistance of the coil, and it is this change in electrical resistance which constitutes the signal from the sensor.



Pellistors are always manufactured in pairs, the active catalysed element being supplied with an electrically matched element which contains no catalyst and is treated to ensure no flammable gas will oxidise on its surface. This "compensator" element is used as a reference resistance to which the sensor's signal is compared, to remove the effects of environmental factors other than the presence of a flammable gas.

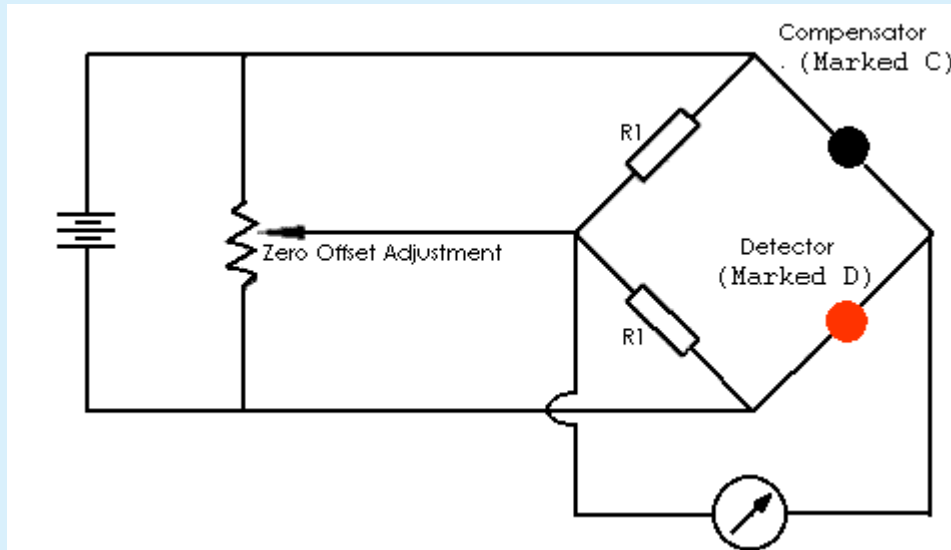

Pellistor Drive/Measurement Circuit: A simple Wheatstone Bridge to compare the resistance of two hot elements

The advantage of using this technique when detecting flammable gases for safety purposes is that it measures flammability directly.

Nemoto provides matched pair pellistors conveniently mounted in a variety of enclosures for different applications. Some of these options contain the detector and compensator elements in separate enclosures (the NP range for Industrial safety applications). In the case of the NAP-78SU, both elements are contained within a special heat resistant enclosure for ease of use and low cost, whilst the external circuit is supplied on-board the device. The circuit is modified slightly from the diagram above to ensure stable and repeatable performance across the very wide range of temperatures required for this application.

Catalytic pellistor type gas sensors have many advantages to semiconductor type gas sensors

- ❖ Linear output in proportion to gas concentration
- ❖ Greater Stability
- ❖ Higher reproducibility
- ❖ Gas specific - will only respond to flammable gases
- ❖ Unaffected by humidity
- ❖ Stable output for long periods
- ❖ More resistant to shocks and vibrations.



General Specifications:

| Operating Specifications: | |
|---|--|
| Detected Gases | Carbon Monoxide and Hydrogen within boiler flue gas streams |
| Standard Concentration Range | 0-1% Carbon Monoxide (0-10,000ppm) |
| Recommended Bridge Voltage | 2.0V +/- 0.05V |
| Current Consumption (at Recommended Bridge Voltage) | 140-160 mA @ 2V Bridge Voltage |
| Bridge zero offset (Measured at 23° C) | +30mV +/- 3mV (see note) |
| Zero shift between 23° C and 200° C | < +/- 1.0mV @ 100° C < +/- 1.0mV @ 150° C < +/- 1.7mV @ 200° C |
| Typical Output Sensitivity (For a Gas Mixture of 1000ppm CO / 500ppm H ₂) | At 23° C: 6mV +/- 1mV At 140° C 4.5mV +/- 0.8mV |
| Linearity | Effectively Linear to 1% CO |
| Response Time (Measured as T ₉₀ for a step change from Air to 1000ppm CO / 500ppm H ₂) | <60 seconds |
| Accuracy (Measured as Repeatability) | ± 0.5mV for Zero ± 0.5mV for Gas Sensitivity |
| Long Term Stability Drift | Zero: Less than +/- 2mV per year Sensitivity: Less than +/- 2mV per Month |
| Expected Lifetime in the field | Over 10 Years. |
| Environmental Specifications: | |
| Temperature Range (Parts Mounted Inside the Flue Duct) | -20°C to +200°C (Maximum 260°C) |
| Temperature Range (Parts Mounted Outside the Flue Duct) | -25°C to +70°C |
| Standard Constant Humidity Range | 0 to 95%RH, non-condensing |
| Standard Constant Pressure Range | 1atm ± 10% |
| Recommended storage Temperature Range | -30 to +70 degree C |
| Recommended Maximum Flow rate (Wind Velocity) | 0.5 m/sec |
| Recommended Maximum Storage Time | 6 months |
| Mechanical Data | |
| Sensor Enclosure Material | 304 SS |
| Connector Pin Material | Nickel |
| Base Header Material | Heat Resistant Phenolic Resin |
| Protective Mesh Material | 316 SS |
| Weight | 24g |



Dimensions and Structure:

Dimensions:

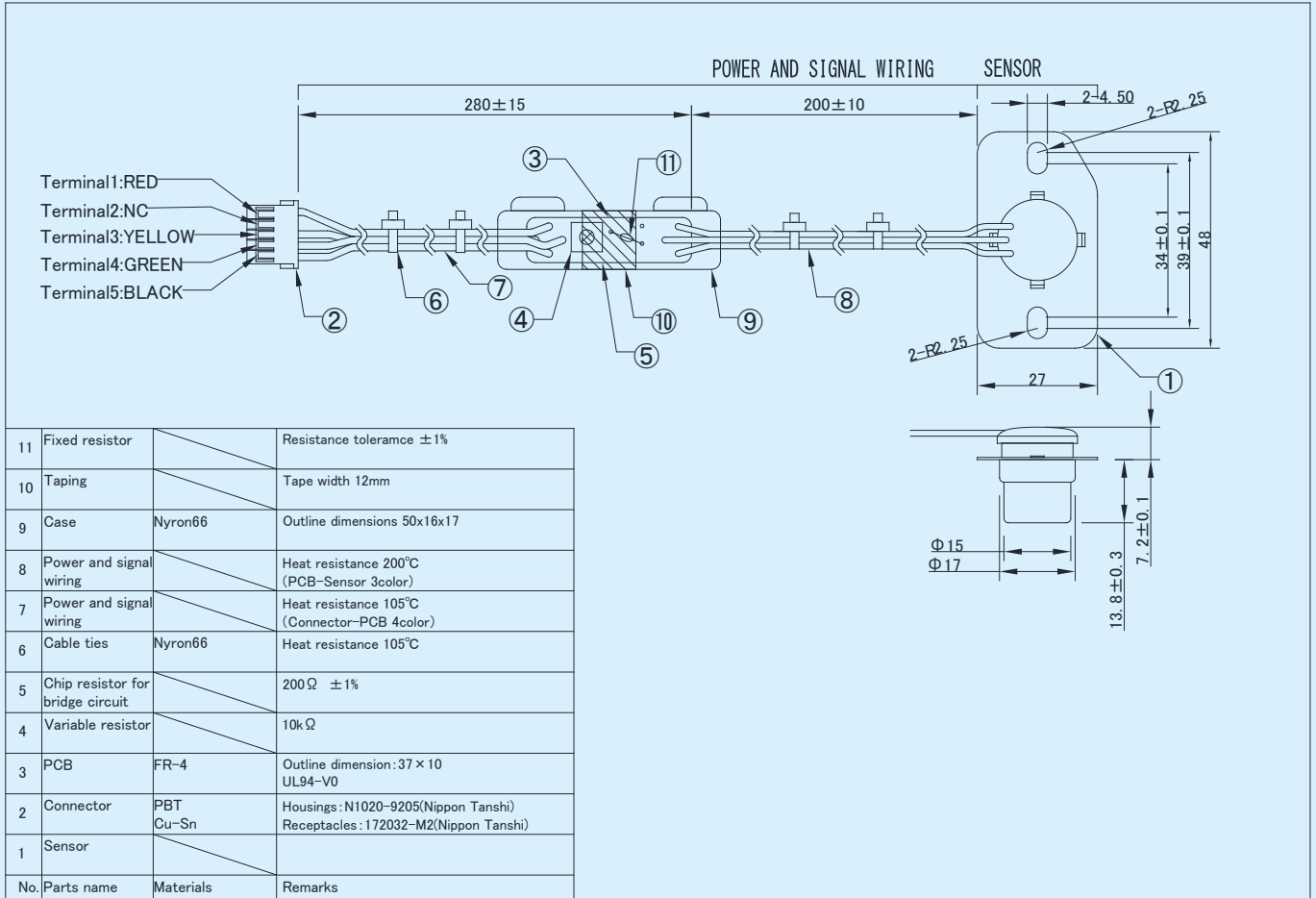



Sensor Structure:

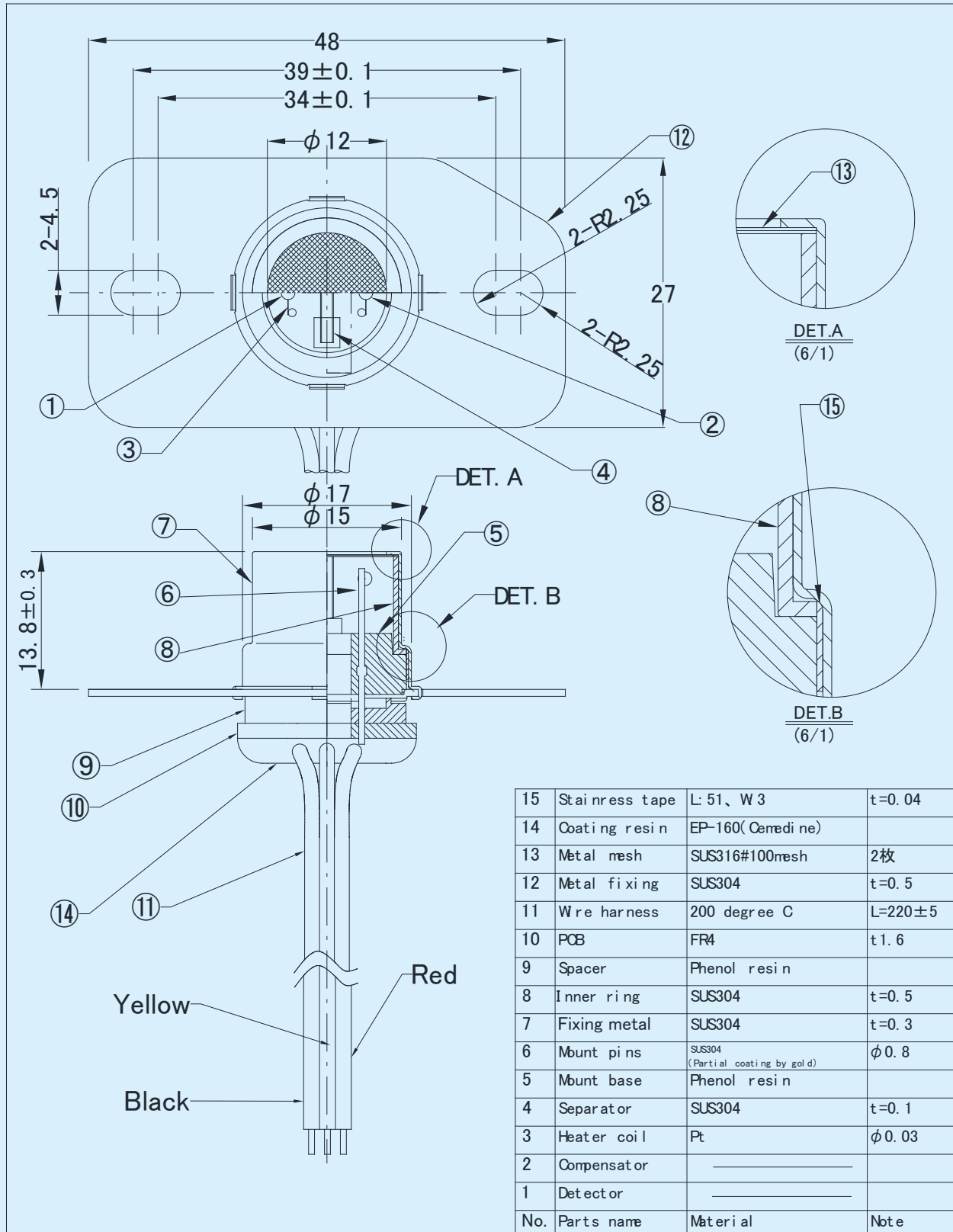



Results of Performance Tests

The information contained in this section is for guidance purposes only and should not be considered part of the specification of the NAP-78SU Gas Sensor for legal or warranty purposes.

Gas Sensitivity and Linearity (Measured at room temperature)

The following graph illustrates the sensitivity to a 2:1 mixture of Carbon Monoxide and Hydrogen:

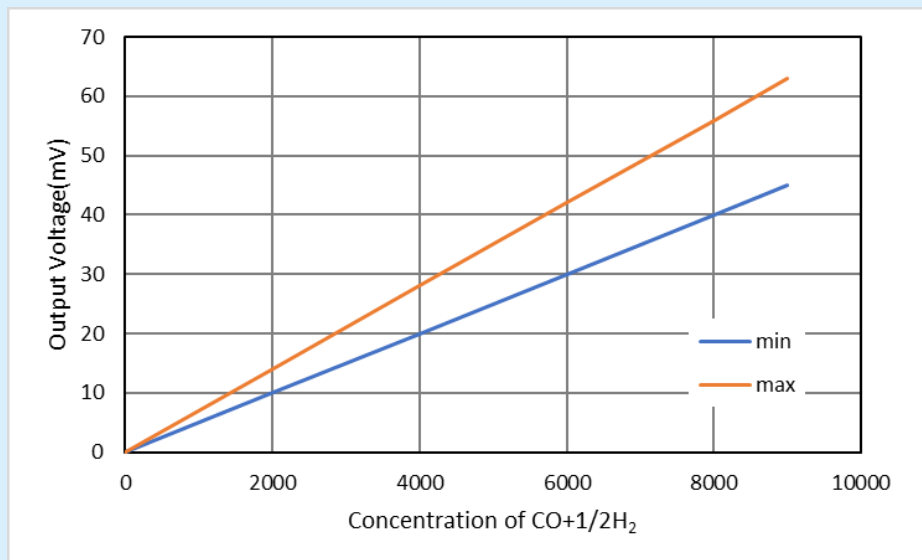

Durability

The NAP-78SU sensor has been designed and tested vigorously to ensure that it can tolerate a range of arduous conditions:

Storage in low temperature: Sensors have been stored at temperatures of -30°C for 1 month.

Storage in high temperature: Sensors have been stored at temperatures of +80°C for 1 month.

Tolerance to High Humidity: Sensors have been stored in 50°C and 98%RH for 48 hours.

Prolonged Storage Time: Sensors have been stored for 6 months in normal ambient conditions.

Catalyst Poison Resistance: Sensors have been exposed to 10ppm Hexamethyldisiloxane (HMDS), a commonly encountered silicone which is known to poison noble metal catalysts.

After all of the above environmental conditions, the NAP-78SU was tested for Span and Sensitivity. In all cases the sensors showed the following results:

| Gas Concentration | Working Temperature | Result following Environmental Test |
|------------------------------------|---------------------|-------------------------------------|
| 0 ppm (Air) | 23°C | Initial Value +/- 1.5mV |
| | 100°C | Value at 23°C +/- 1mV |
| | 200°C | Value at 23°C +/- 1mV |
| 1000ppm CO / 500ppm H ₂ | 23°C | Initial Value +/- 0.7mV |
| | 140°C | Initial Value +/- 0.5mV |



Temperature Dependence

Bellow is an illustration of the Temperature dependence of the NAP-78SU sensor for span sensitivity to 1000ppm CO / 500ppm H₂. The graph assumes the sensitivity at 23°C is 100

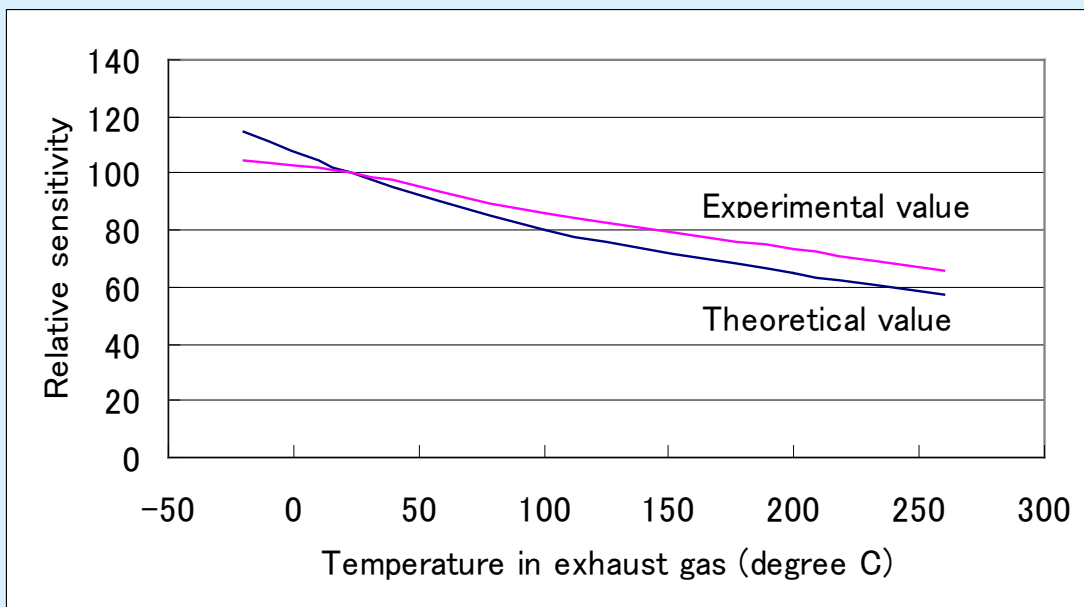

Response to Hydrogen:

The plot below illustrates the sensitivity to Hydrogen, in a balance gas of CO: 1000ppm, H₂O:12%, CO₂: 7.5%, O₂ : 7.5%, Balance N₂.

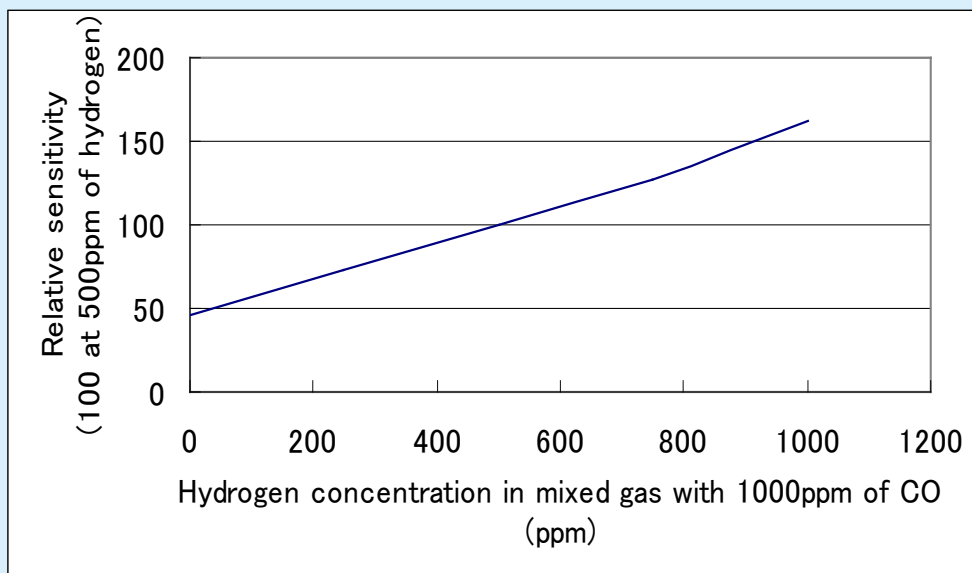



Tolerance to Temperature Transients (Heat Shock)

Sensors have been stored at -30°C for 2 hours then suddenly transferred to an environment of 80°C degree C for 2 hours. This temperature cycle was repeated 700 times. Following the temperature cycling, all components and joints were examined very closely for signs of physical damage, including solder connections. The sensors were also tested for Zero and Gas Sensitivity. No significant effect was noted on the either the structure or the performance of the sensors.

Tolerance to Vibration

Sensors were subjected to a vibration of 10 Hz, Amplitude 5mm, 1G in all three planes X, Y and Z for 20 minutes. No effect on performance or structural integrity of the device was detected following the vibration.

Tolerance to Corrosive Gases

Sensors have been tested thoroughly for long periods in gases containing SO₂. and NO₂ gases. No significant effect on the performance of the sensor has been noted. Nemoto is confident that, at the levels encountered in normal flue gases, these gases will have no detrimental effect to the performance of the sensor.

Initial Start-up time and optional Heat Cleaning Cycle

On initial power-up, the NAP-78SU sensor will normally stabilize to a workable zero offset within 2 minutes. However, when powered-up for the first time following storage or a long period of inactivity, catalytic type gas sensors can sometimes take several hours to completely stabilize to their final zero offset point.

For most applications, the initial stabilization time, even after long periods of storage, presents no problem since the zero stability after 120 seconds is within acceptable limits. However, if very high accuracy is required immediately following initial power-up, the stabilization of the sensor can be hastened by the application of a higher power supply (2.75V is recommended) for the first 30 seconds of operation, followed by the normal operating power supply. This "Heat Cleaning Cycle" will result in the sensor reaching its final zero reading more quickly than if it had the operating voltage applied only.

The plot below illustrates the initial stabilization of sensors when powered for the first time following 30 days of normal storage.

It can be seen that by using a heat cleaning cycle the gain in initial stabilization time is very slight and for most purposes the heat cleaning option gives little benefit.

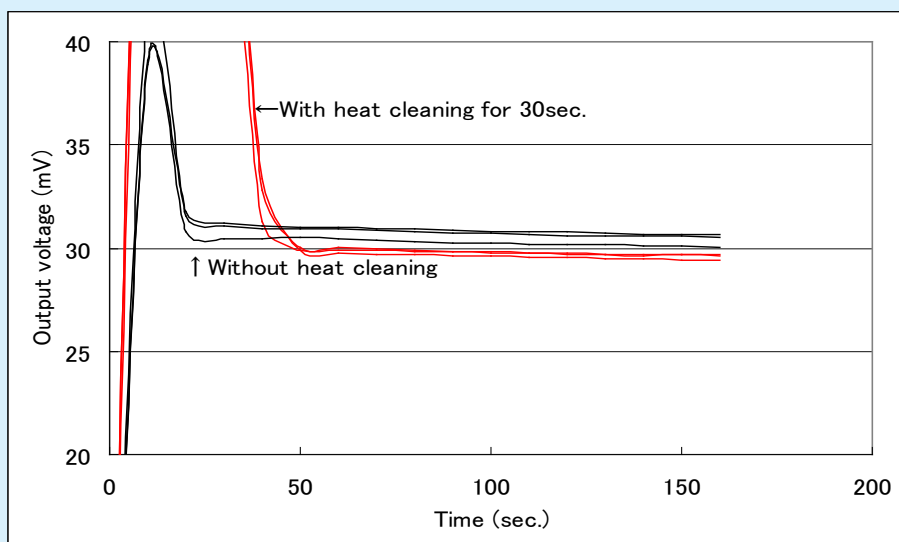



Long Term Stability and Periodic zero correction

The following plots represent the typical long-term stability of the NAP-78SU in a real working situation within a water heating boiler. Note that this data is based on a 20 minutes on, 5 minutes off duty cycle.

Zero Offset:

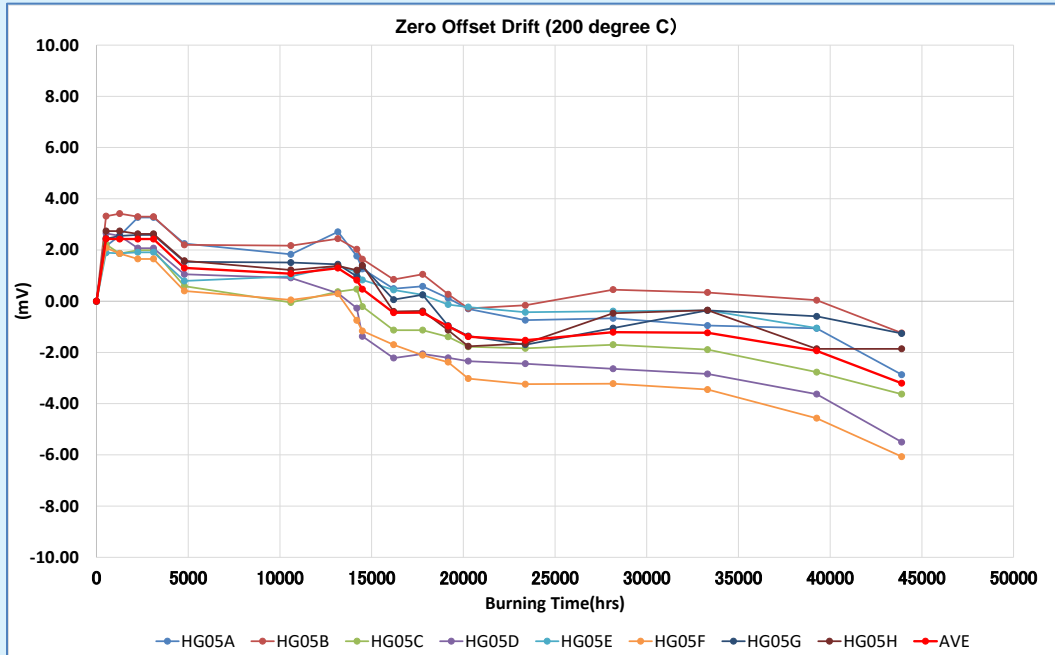

Gas Sensitivity:

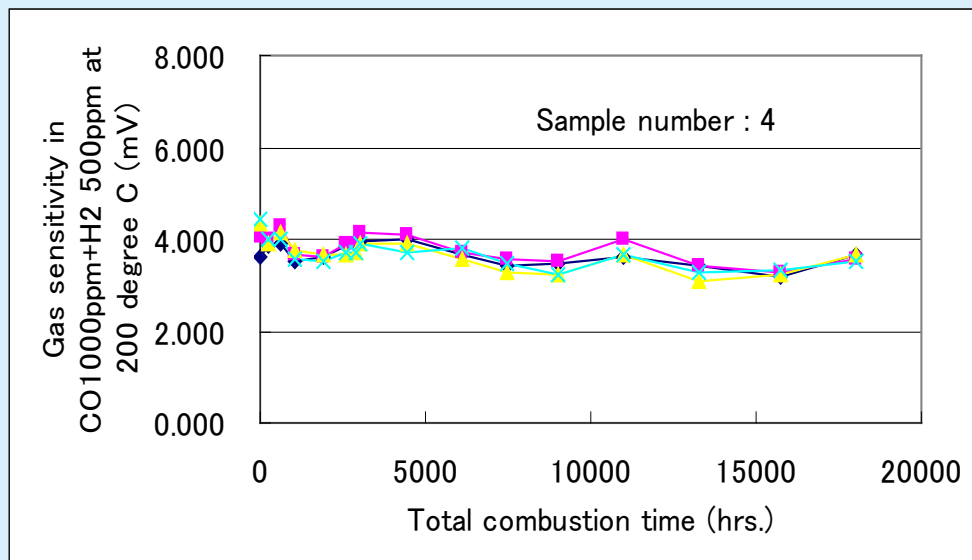

Note that Gas sensitivity = [mV signal in Gas] – [mV zero offset]

Although the Gas Sensitivity of the sensor does not change significantly during the sensor's lifetime in a real working situation, the zero offset does drift slightly with time. This should be compensated for in the software of the appliance by carrying out a routine zero correction calibration during periods where the force ventilation of the flue is running but the burner is inactive, ensuring that no combustion gases are in the flue of the boiler during this procedure.

These regular zero adjustments are important to maintain the sensors accuracy, preventing false alarms, and could be carried out, for example, whenever the appliance is switched on, just before the burner is ignited.



Notes for Designers.

1) **Sensor Fault Diagnosis:**

It is recommended that the sensor is monitored for the unlikely event of an open-circuit or short circuit-fault during the lifetime of the appliance. In the case of an open-circuit fault, the zero-offset signal of the sensor will change to close to either -1V or +1V. In the case of a short circuit fault, the sensor's zero offset signal will change to either 0V or 2V.

It is therefore recommended that if the zero offset voltage changes to less than 0V (i.e. a negative value) or more than 150mV, then the appliance should signal a fault and the sensor should be replaced.

2) **Initial start-up:**

When a gas water heating boiler is started up, sometimes the initial burning produces a temporary higher level of CO in the flue which is perfectly normal and non-hazardous. The designer should therefore consider including in the software that the signal from the sensor is ignored for the first 30 seconds of operation after the burner is switched on.

3) **Mounting Position of the Sensor:**

The NAP-78A operates most correctly mounted on the flue (stack) of the appliance according to the following diagram:

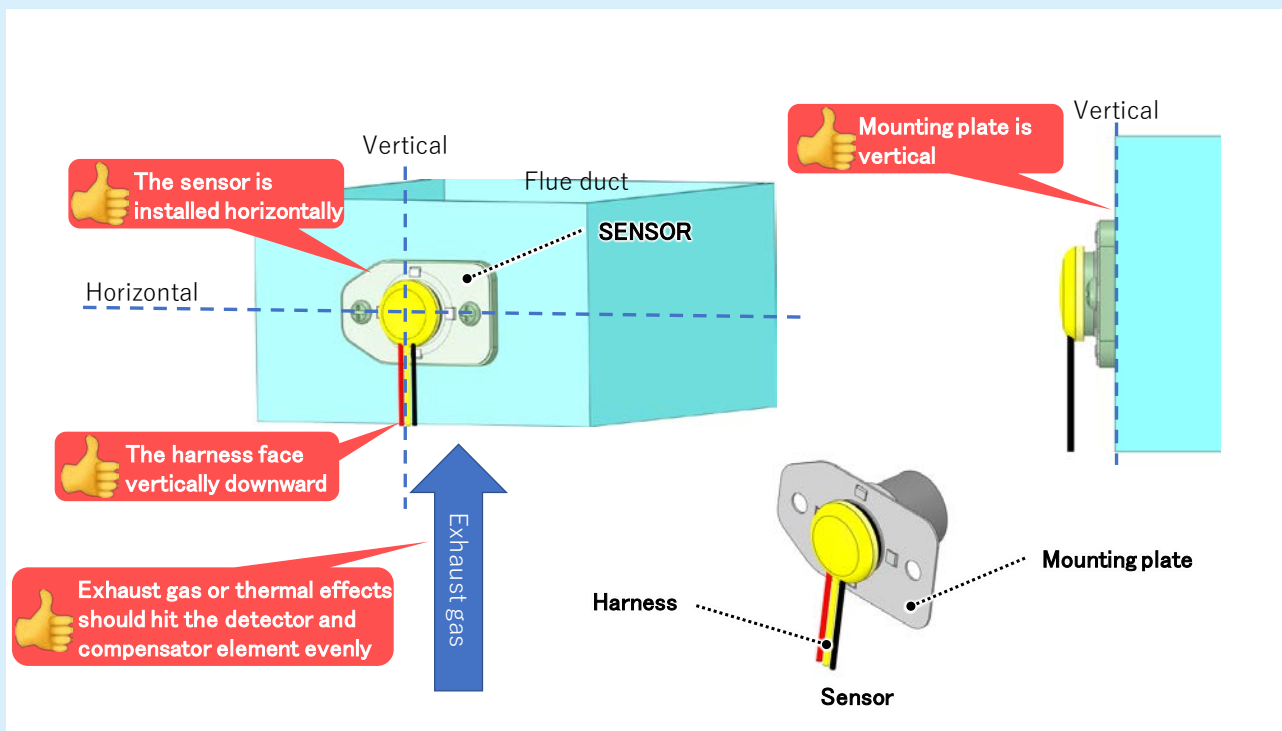

Correct Mounting Of the NAP-78SU

The mounting holes of the sensor should be Horizontal, with the sensor harness (cable) pointing vertically downward, whilst the flue bulkhead and direction of flow and of the gas within the flue should be vertical.

Examples of incorrect mounting are shown on the next page:

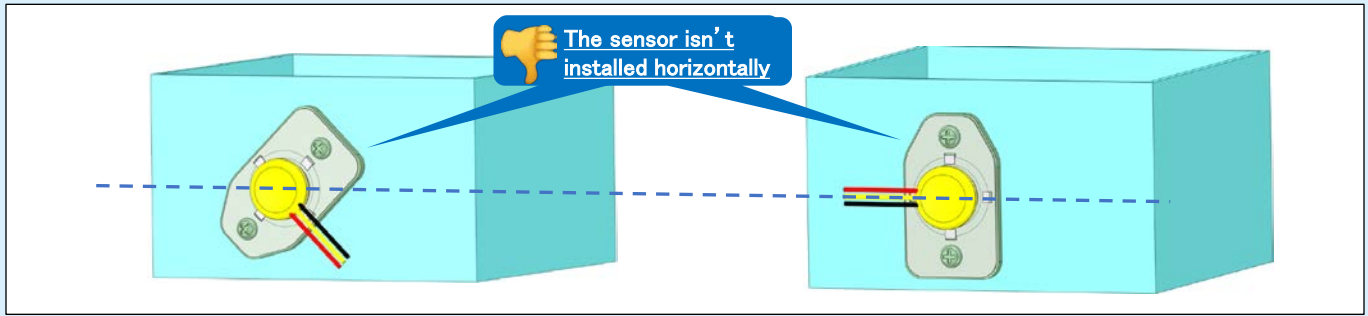

Incorrect Mounting – Sensor not horizontal

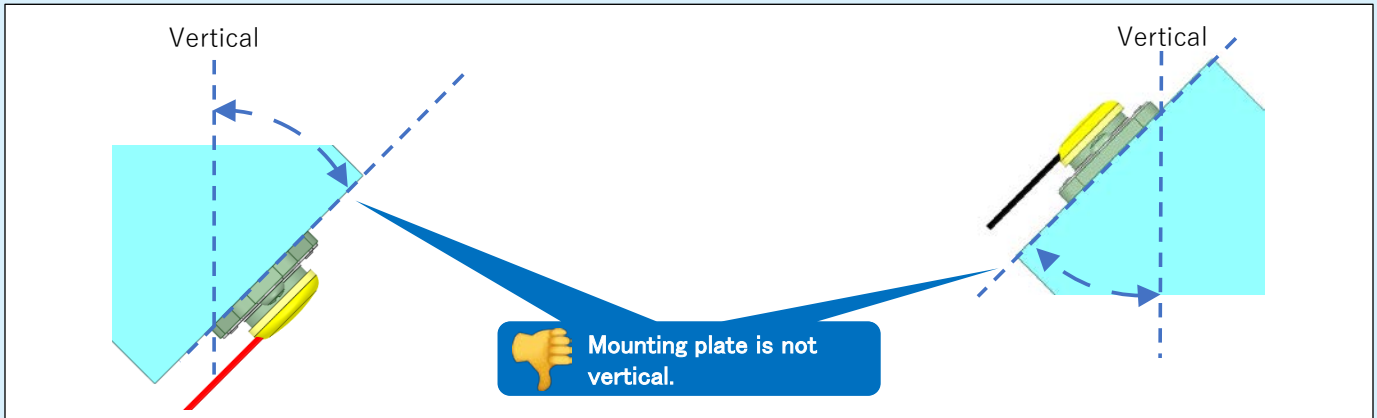

Incorrect Mounting – Mounting bulkhead not vertical

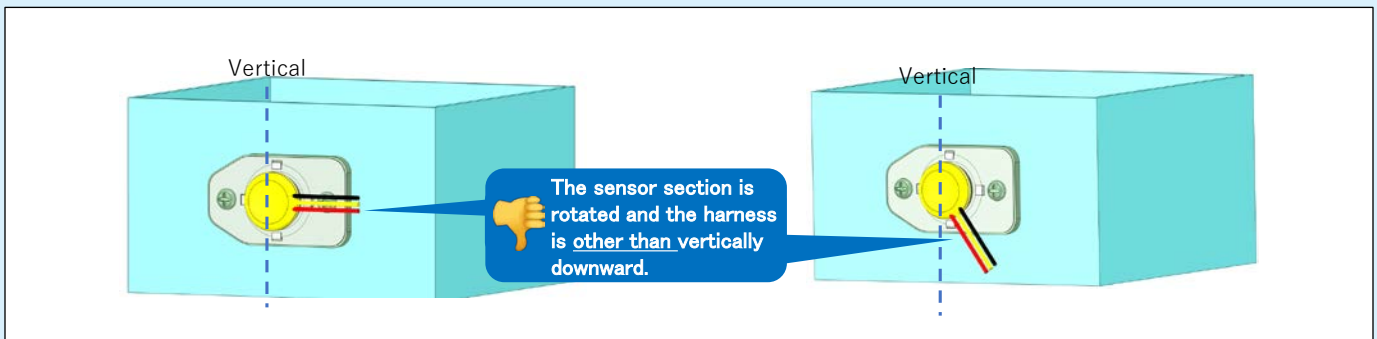

Incorrect Mounting – Sensor assembly twisted – sensor harness and cable should be directed vertically downward

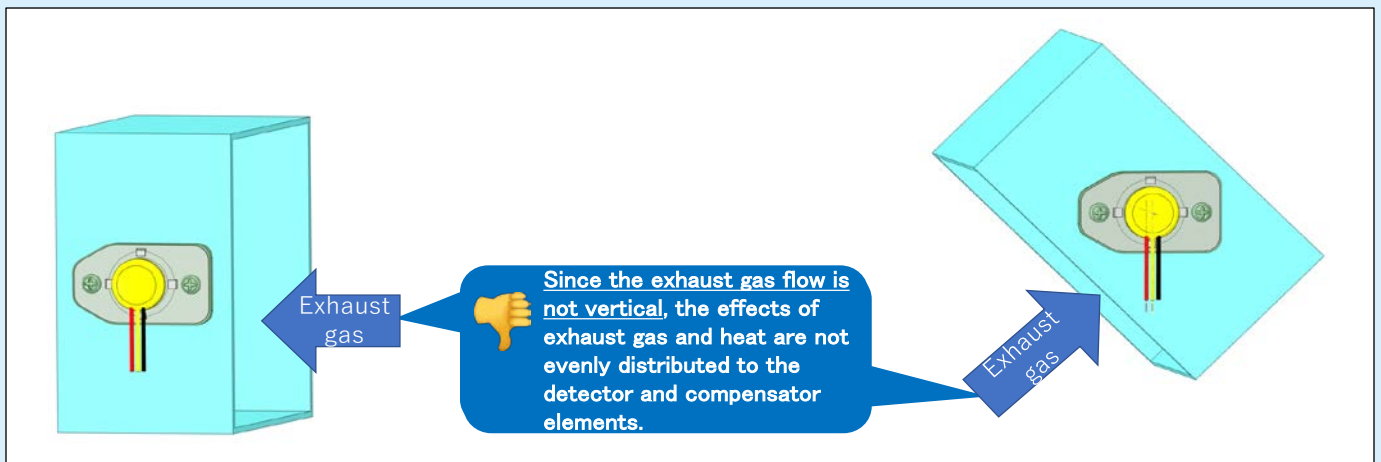

Incorrect Mounting – Sensor Mounted horizontally but direction of gas flow not vertical



The position of the sensor should be chosen to maximise its sensitivity and response time, whilst avoiding turbulent flow of gas at the sensor during operation if possible.

The flow velocity of the gas in the flue where the sensor is mounted should be less than 0.5 m/s

The sensor should also be as far away as possible from other electrical parts of the appliance to minimise interference and RF electrical noise in the sensor signal.

If necessary, the sensor should be provided with gasket seal to ensure that flue gases do not escape from the flue.

One arrangement which has been found to be successful is to mount the sensor in its own housing, with 1-2mm hole punched into the bulkhead of the flue to allow gas from the flue to diffuse into it, as in the arrangement illustrated below:

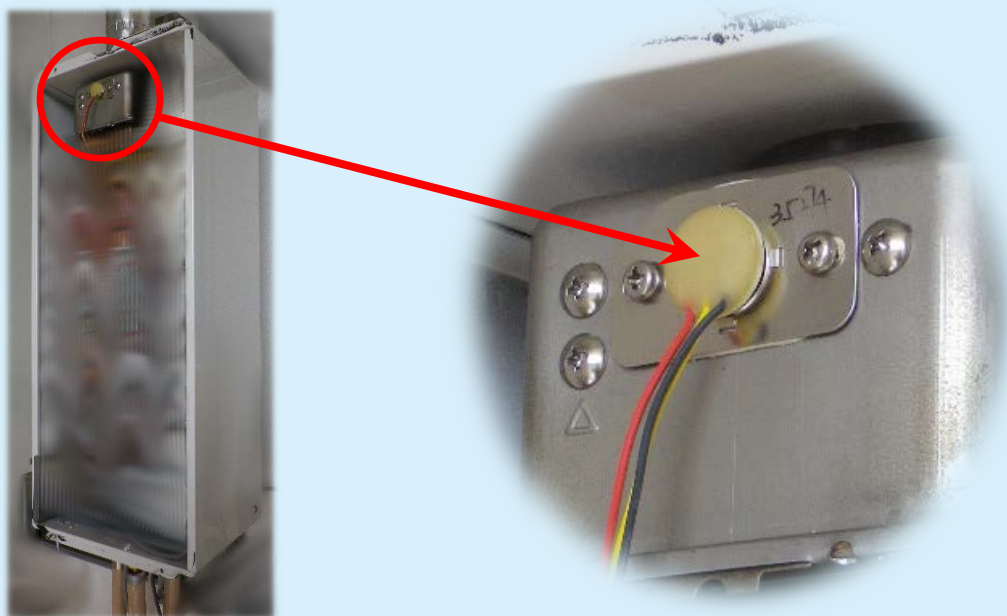

This arrangement will allow gas from the flue to diffuse to the sensor, allowing measurement to take place without interference from turbulent flows in the flue itself, and also protecting the sensor from condensing conditions.

- 4) It is recommended that the sensor is permanently energised. This means that even when the appliance is not being used, the sensor remains energised and operating normally.
- 5) Since the detection of incomplete combustion by the sensor will result in the appliance being automatically shut down, it is recommended that a time weighted average measurement is used to verify the signal from the sensor. This will eliminate the slim possibility of false alarms caused by electrical noise spikes from pumps, switches etc within the appliance.
- 6) Do not use the sensor in the presence of other flammable gases or vapours, such as solvents, lubricants, degreasants used in the manufacturing of the appliance.
- 7) Care should be taken, during transportation, manufacturing processes and use, not to subject the sensor to undue shocks or vibrations. Power tools should not be used to install the device.
- 8) Do not pull on the harness or twist the sensor assembly within its mounting plate.
- 9) Care should be taken to avoid the sensor being exposed to water condensation.



Circuit Layout

The diagram on the following page illustrates the basic circuit and mode of operation of the NAP-78SU.

“C” and “D” are the compensator and detector elements of the device.

RT1 and RT2 indicates that a resistor is placed here (by Nemoto) in parallel with the Detector element or Compensator element (but not both). Both alternatives are illustrated here (Fig 1 and Fig2). Occasionally no resistance may be required or fitted. The function of this resistor is to provide temperature compensation to ensure that the zero baseline at ambient temperature is the same as at the hot working temperature of the boiler. Nemoto determines the correct resistance value individually for each device and fits the resistor accordingly.

R1 and R2 are simple balancing resistors, to balance the Wheatstone bridge.

VR1 is a variable resistance which provides a second stage zero correction. The raw zero specification of the sensor, if VR was not fitted, would be approximately as +20mV to +90mV, and VR1 is pre-adjusted by Nemoto to give a zero offset of +30mV. Nemoto may supply the NAP-78SU sensor with customer specified zero offset if required. It is therefore recommended that VR1 is NEVER adjusted.

The NAP-78SU is provided with a 5-pin connector, assigned as follows:

| | |
|--|--------------------------------|
| Terminal 1 (to the Red wire): | Power supply (+2V) |
| Terminal 5 (to the Black wire): | Power supply Ground (GND) |
| Terminals 3 and 4 (to the Yellow and Green wires): | The mV signal from the sensor. |
| Terminal 2 is not used. | |

Note that the signal –ve connection (pin 5) must not be connected to GND. The power and signal connections must remain isolated.

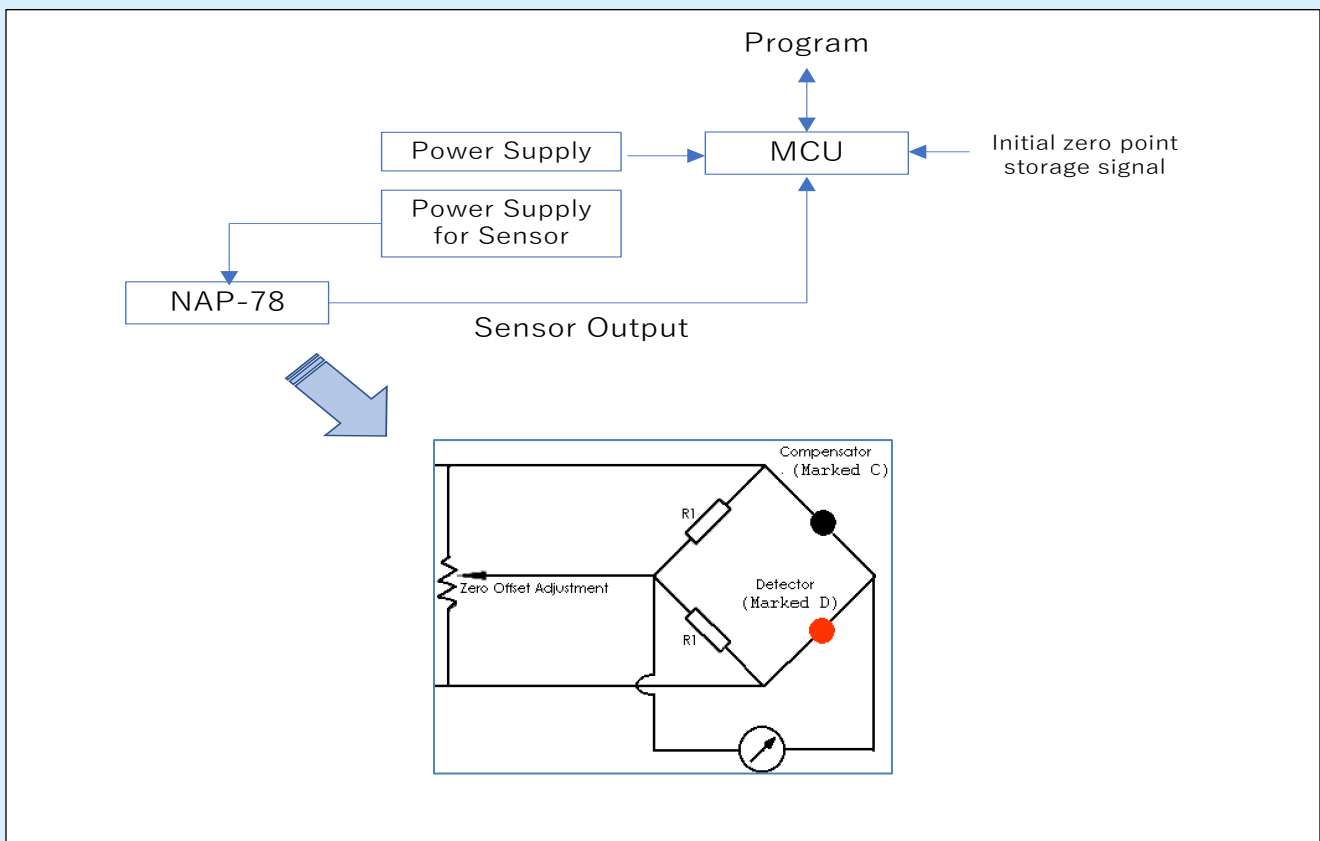

Typical schematic layout within an appliance

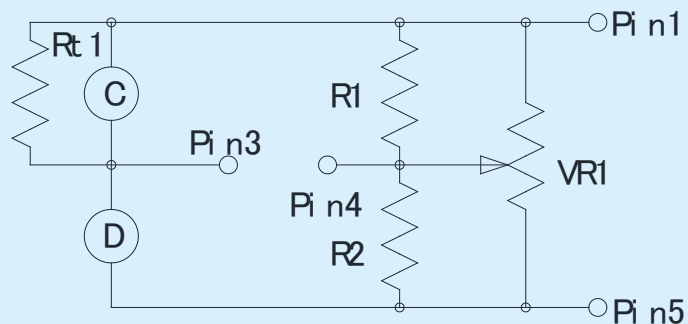

Fi g. 1

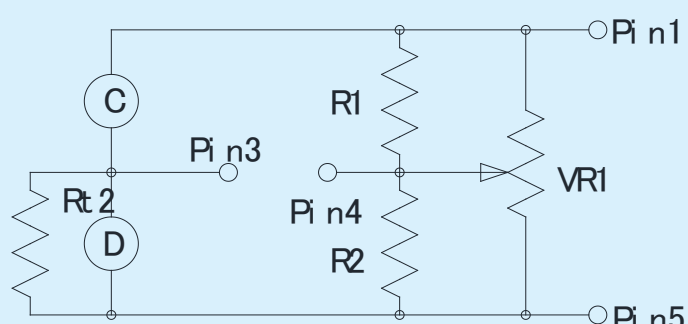

Fi g. 2

Note:
 NAP-78S is produced by connection Fig. 1 or either way of connection Fig. 2 according to an individual temperature characteristic test result.

| | |
|--------|-------------------------------------|
| Pi n5 | Connector input (0V) |
| Pi n4 | Connector output (-) |
| Pi n3 | Connector output (+) |
| Pi n1 | Connector input (2V) |
| C | Sensor (Compensator) |
| D | Sensor (Detector) |
| Rt 1 | Fixed resistor |
| Rt 2 | Fixed resistor |
| VR1 | 10k Ω Variable resistor |
| R1, R2 | 200 Ω \pm 1% Chip resistor |

Internal Circuitry of NAP-78SU

Note that sensors are fitted with either Rt 1 or Rt 2, but not both.