



Nemoto & Co., Ltd
Sensor Division

4-10-9 Takaido-Higashi
Suginami-ku
Tokyo 168-0072,
Japan

www.nemoto.eu

NCP-180S-7S Explosive/Flammable Gas Sensor

Operating Characteristics and Handling Manual

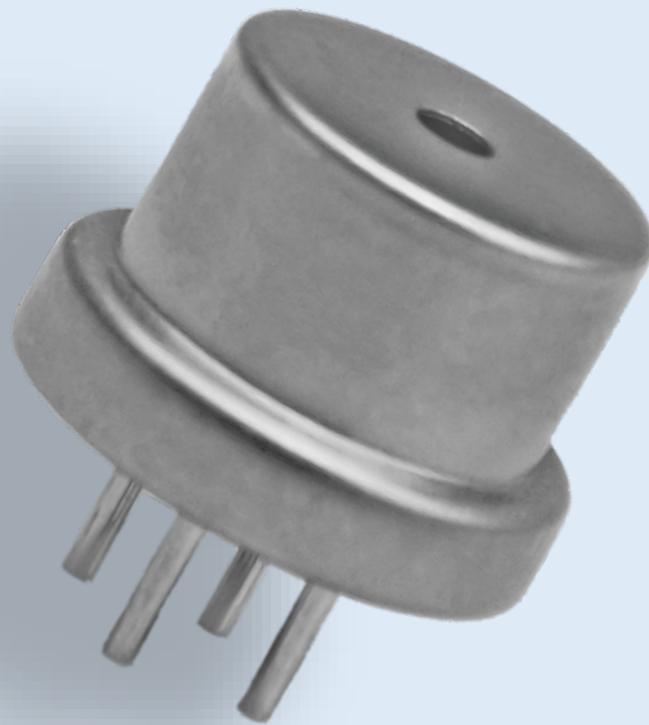

The NCP-180S-7S is a new Catalytic (pellistor) type flammable gas sensor supplied as a matched pair of pellistor elements mounted on a single header and protected by a metal enclosure and can.

The sensor detects and measures the presence of flammable gases and vapours in air, in the range 0-100%* of the Lower Explosive Limit (LEL) of the gas or vapour being measured. Designed for use in Fixed Gas Detection Systems, we believe the NCP-180S-7S offers an unparalleled combination of high performance and low-cost.

The NCP-180S-7S is closely related to the established NCP-180S-6S sensor, but is modified to exhibit a slightly lower signal output sensitivity, resulting in excellent long term zero and sensitivity stability, improved linearity over the entire range 0-100% LEL, and a higher level of resistance to catalytic poisons. We believe the result is the best performing and most cost effective Industrial pellistor for fixed systems available from anywhere.



Contents

Principles of Operation.....	3
General Specifications.....	4
Outline Drawing and construction.....	5
Zero drift with temperature and Optional use of Trimming Resistor.....	6
Performance Measurements.....	8
Gas Sensitivity/Linearity.....	8
Temperature Dependence.....	9
Humidity Dependence.....	10
Relative Responses to Various Gases.....	11
Sensitivity Distribution.....	12
Poison Resistance.....	12
Recovery from Silicone Poisoning.....	13
Exposure to Overrange Conditions.....	13
Shock and Vibration resistance.....	13
Storage and Operation in extreme Environmental Conditions.....	14
Notes on Sensor Testing.....	15

Nemoto & Co., Ltd
Sensor Division
4-10-9, Takaido-Higashi, Suginami-ku, 168-0072 Tokyo
TEL. 81-3-3333-7341
FAX. 81-3-3333-7344
WEB: <http://www.nemoto.eu>

Note that the Performance measurements expressed in this document should be considered as typical characteristics for guidance only, and not as specifications which are guaranteed, apart from those in the sections "General Specifications" and "Dimensions" (Pages 4 and 5). It is the instrument designer's responsibility to ensure that the sensor is suitable for any given application.

Nemoto has a policy of continuous development and improvement of its products. As such the specification for the device outlined in this document may be changed without notice.



Principles of Operation:

Catalytic combustion has been the most widely used method of detecting flammable gases in Industry since the invention of the catalysed pelletized resistor (or "Pellistor") over 40 years ago.

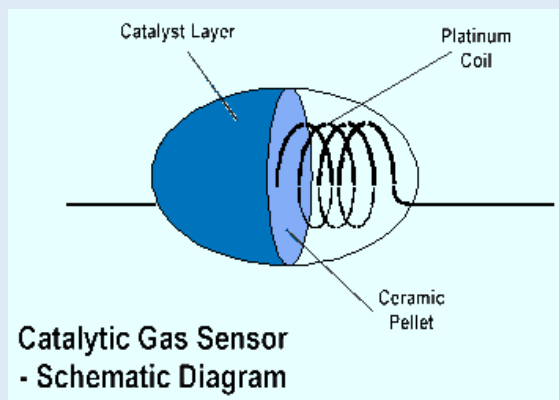

A Pellistor consists of a very fine coil of platinum wire, embedded within a ceramic pellet. On the surface of the pellet is a layer of a high surface area noble metal, which, when hot, acts as a catalyst to promote exothermic oxidation of flammable gases. In operation, the pellet and so the catalyst layer is heated by passing a current through the underlying coil. In the presence of a flammable gas or vapour, the hot catalyst allows oxidation to occur in a similar chemical reaction to combustion. Just as in combustion, the reaction releases heat, which causes the temperature of the catalyst together with its underlying pellet and coil to rise. This rise in temperature results in a change in the electrical resistance of the coil, and it is this change in electrical resistance which constitutes the signal from the sensor.

Pellistors are always manufactured in pairs, the active catalysed element being supplied with an electrically matched element which contains no catalyst and is treated to ensure no flammable gas will oxidise on its surface. This "compensator" element is used as a reference resistance to which the sensor's signal is compared, to remove the effects of environmental factors other than the presence of a flammable gas.

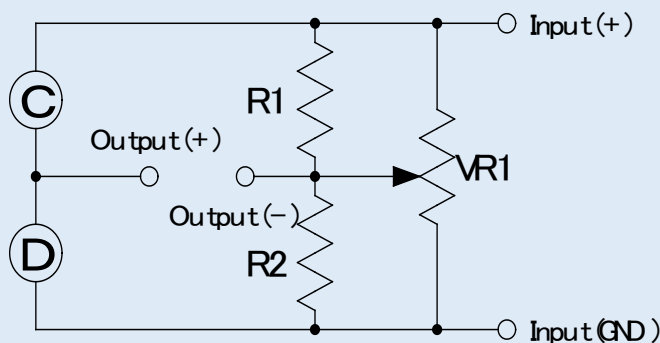

Pellistor Drive/Measurement Circuit: A simple Wheatstone Bridge to compare the resistance of two hot elements

The advantage of using this technique when detecting flammable gases for safety purposes is that it measures flammability directly.

Nemoto provides matched pair Pellistors conveniently mounted in a variety of enclosures for different applications. Some of these options contain the detector and compensator elements in separate enclosures (the NP range for Industrial applications). In the case of the NCP-180S-7S, both elements are contained within a metal enclosure mounted on a phenolic resin header for ease of use and low cost.



Catalytic pellistor type gas sensors have many advantages compared with semiconductor type gas sensors

- ❖ Linear output in proportion to gas concentration
- ❖ Greater Stability
- ❖ Higher reproducibility
- ❖ Gas specific - will only respond to flammable gases
- ❖ Unaffected by humidity
- ❖ Stable output for long periods
- ❖ More resistant to shocks and vibrations.

General Specifications:

Operating Specifications:	
Detected Gases	Flammable Gases (Specifications are based on the detection of Methane/Natural Gas)
Standard Concentration Range	0-100% LEL
Recommended Bridge Voltage	2.5V +/- 0.1V
Current Consumption (at Recommended Bridge Voltage)	170mA +/- 20mA
Bridge zero offset	0 +/- 30mV
Minimum Output Sensitivity	15 mV for 1% CH₄
Linearity	Effectively Linear to 100% LEL (Please see the relevant section later in this manual)
Response Time (Measured as T90)	<10 secs
Accuracy (Measured as Repeatability)	± 0.5mV for Zero ± 1% LEL for Gas Sensitivity
Long Term Stability Drift	Sensitivity: Less than +/- 1% LEL / month Zero: Less than +/- 0.75mV / month
Zero Drift with temperature: Without Trimming resistor With Trimming resistor (see explanation on pages 6-7)	<+/- 4mV between -30°C to +60°C <+/-1mV between -30°C to +60°C
Expected Lifetime in the field	> 3 Years.
Warranty Period	24 Months
Environmental Specifications:	
Temperature Range	-20°C to +60°C
Standard constant Humidity Range	15 to 90%RH
Standard Constant Pressure Range	1atm ± 10%
Recommended storage Temperature Range	0 to 20 degree C
Recommended Maximum Storage Time	6 months
Mechanical Data	
Enclosure Material	Nickel Plated Brass
Connector Pin Material	Nickel
Header (Base) Material	Phenolic Resin



Dimensions and Structure

Sensor : NCP-180S-7S

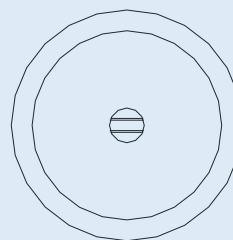
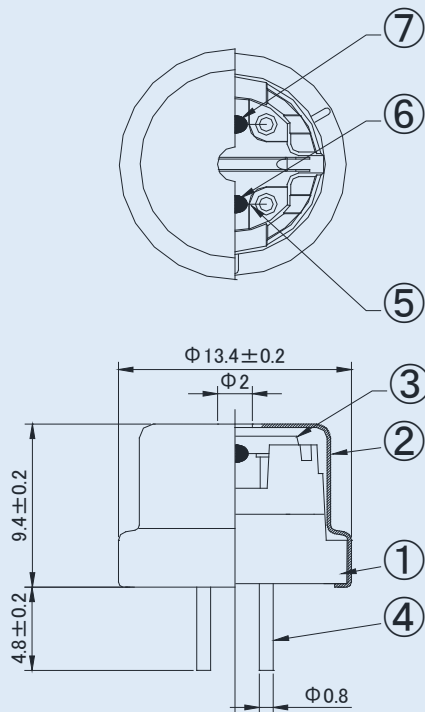

Top view
Detector mark

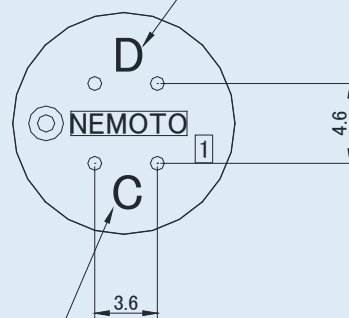

Compensator mark
Bottom view

All Dimensions in mm
Tolerances +/- 0.2mm

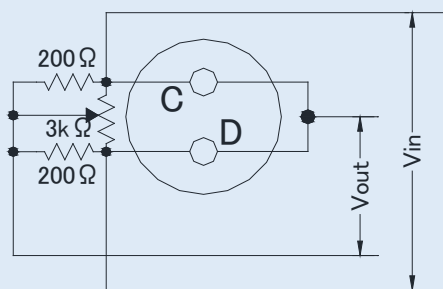

Measuring Circuit

7	Detector	-	Nemoto & Co.Ltd
6	Compensator	-	Nemoto & Co.Ltd
5	Coil	PPT	φ 30um
4	Pin	Pure Ni	φ 0.8
3	Separator	SUS304CSP	t0.1
2	Cap	SUS304	t0.2
1	Mount	Phenolic resin	UL94-V0
No.	Parts names	Material	Remarks



Zero Drift with Temperature, and optional use of Trimming Resistor

In order to obtain the superb linearity, poison resistance and durability to environmental extremes performance of the NCP-180S-7S, the sensor has a very restricted diffusion barrier, resulting in a very low minimum sensitivity of 15mV / 1% Methane. The performance benefits of this are significant, but it does also result in a higher zero drift with temperature in terms of gas concentration. However this can be compensated for by the use of a specific trimming resistor, placed in the circuit **in parallel** with **either** the detector element **or** the compensator element.

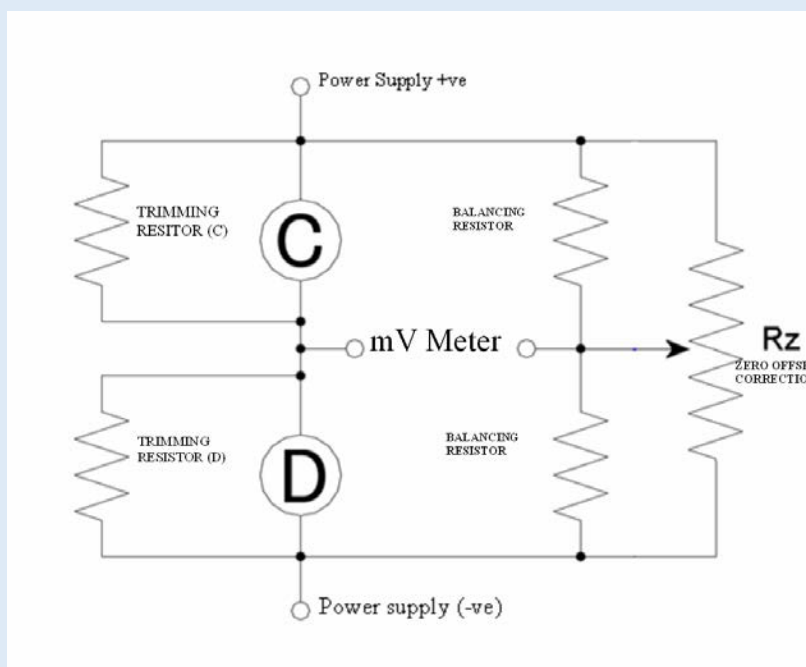

Each NCP-180S-7S sensor has an optimum trimming resistor value marked on the side of the sensor:

XXXXY

Where X = either D or C (denoting **D**etector or **C**ompensator)
YYY = the value of the optional resistor to use.



So, for the example graphic shown, the code C0390 means the recommended trimming resistance for this sensor is 390 Ω , placed in parallel with the **compensator** element. As another example, D0220 would mean the recommended trimming resistance for this sensor is 220 Ω , placed in parallel with the **detector** element. Note that only one of the elements require the resistor, never both.

The use of this trimming resistor is entirely optional, but its use will result in very much improved zero stability with temperature, humidity, time and many other environmental effects. Of course the trimming resistance can be applied to the circuit either manually or via software

Unlike other pellistor manufacturers, the use of this trimming resistor on this Nemoto sensor is **not** to change the fundamental zero offset of the sensor, to balance the bridge or to act as a first stage zero offset correction (although the zero offset will change slightly when you use the trimming resistance). The use of this trimming resistor is **only** to optimise the zero stability performance of sensor with environmental changes. Zero offset correction can then be performed by the use of a variable resistor potentiometer (R_z in the circuit above) or in software in the usual way.



The recommended trimming resistance is always between 0Ω – 1500Ω , and is taken from a choice of 9 values:

1500Ω , 750Ω , 510Ω , 390Ω , 330Ω , 270Ω , 220Ω , 200Ω and 0Ω (meaning no trimming resistor is necessary).

The effect of the use of the optional trimming resistor are shown in the graphs below, showing various typical examples of the zero offset shift with temperature, before and after the application of the trimming resistor:

Zero offset: -23.3mV

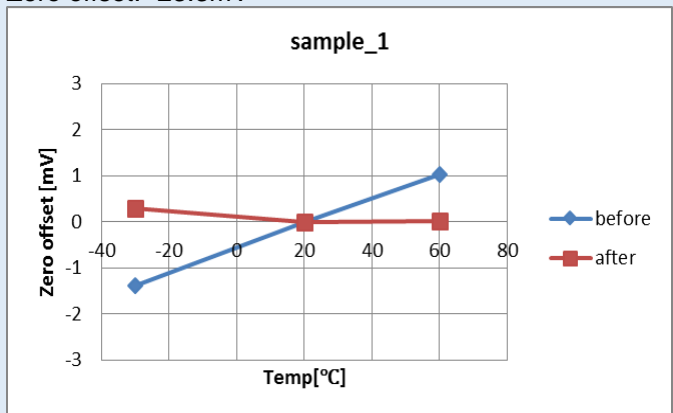

Zero offset: -22.2mV

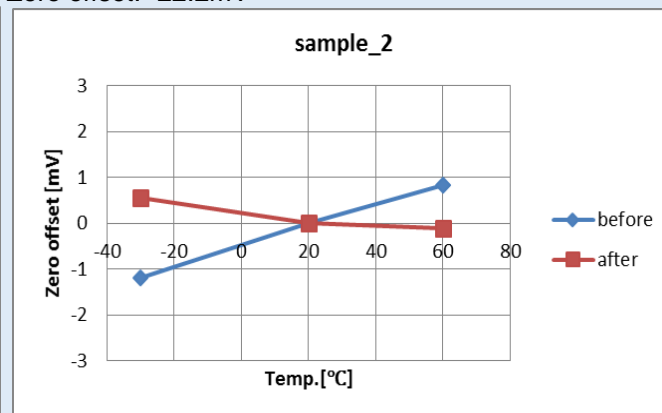

Zero offset: -17.6mV

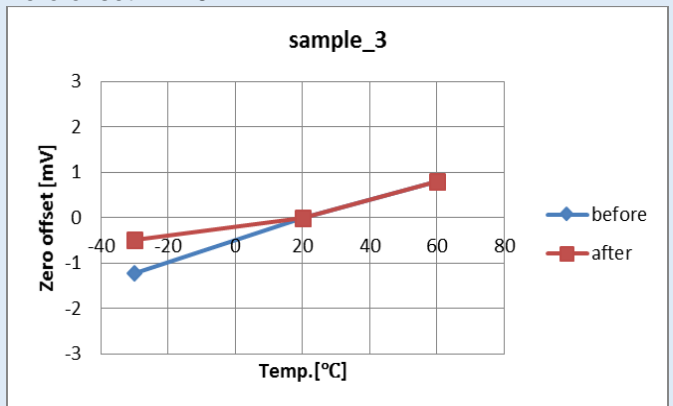

Zero offset: -6.5mV

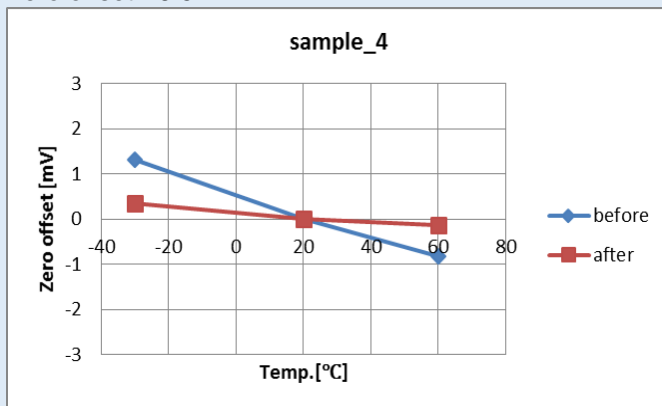

Zero offset: +6.7mV

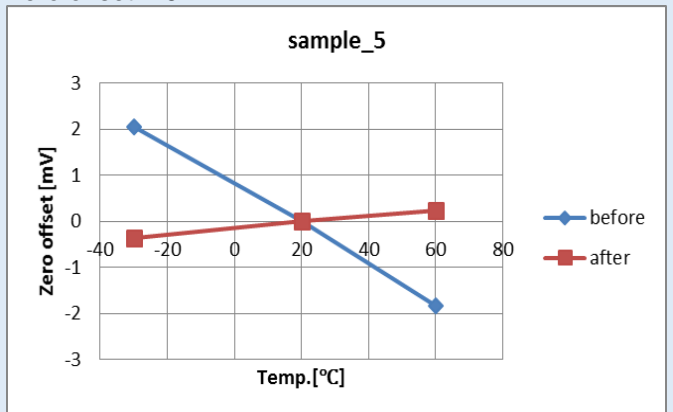

Zero offset: +3.0mV

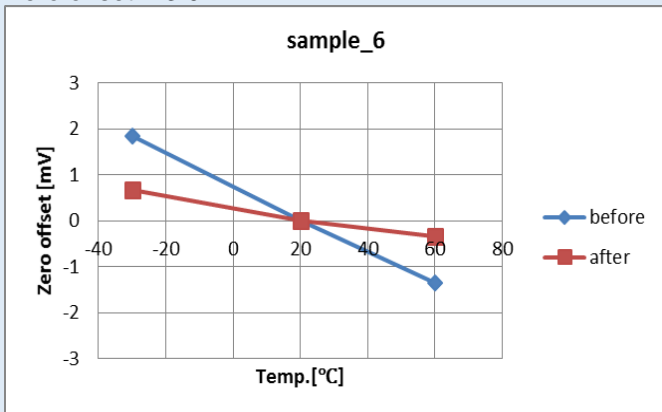



Performance Measurements

The NCP-180S-7S sensor is derived largely from the very popular NAP-56A sensor, the main difference being in the enclosure, which has been redesigned to attain similar performance characteristics to sensors mounted in twin T04 headers. The design brief for the NCP-180S-7S sensor was to achieve these characteristics whilst maintaining the cost benefits of single header design.

The chief performance difference between the two sensors is that the signal output of the NCP-180S-7S sensor is very much lower than the NAP-56A, resulting in a wider usable range of 0-100%LEL, better linearity and very much improved durability to environmental extremes and environments containing catalyst poisons. To offset the lower sensitivity, steps have been taken to reduce noise effects.

Gas sensitivity / Linearity

The graph below shows the typical sensitivity characteristics for methane. One can see that the sensor is not 100% linear (as with all pellistor gas sensors), but the deviation from linearity is small and can be compensated for in software if required. More details on linearity can be supplied on request.

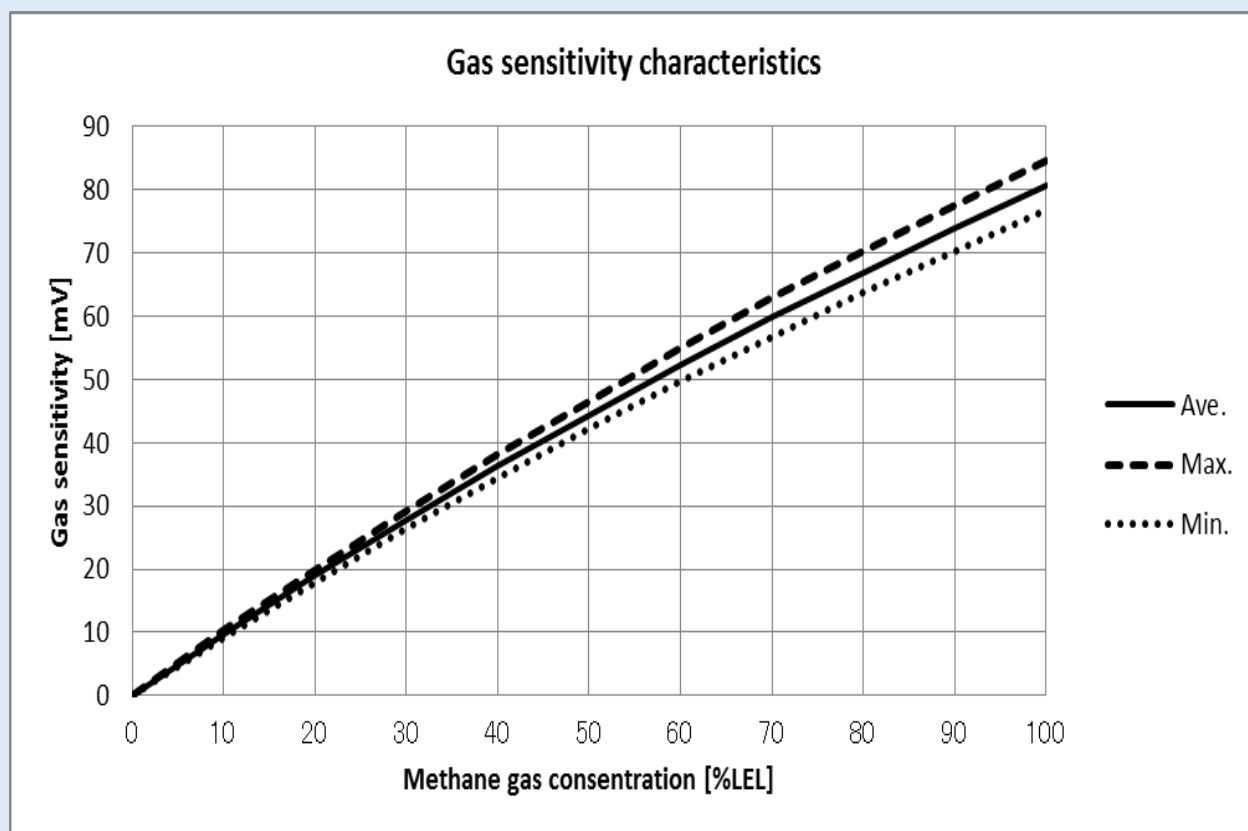



Temperature Dependence:

Typical Zero Offset Drift with Temperature (without Trimming Resistor):

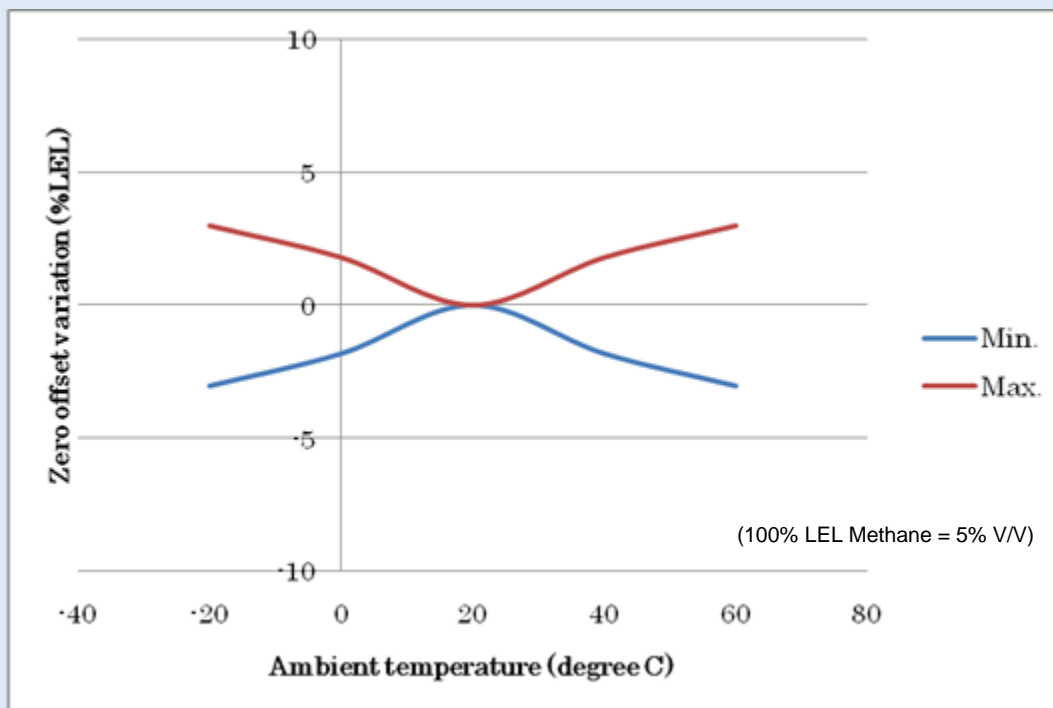

Typical Gas Sensitivity Drift with Temperature:

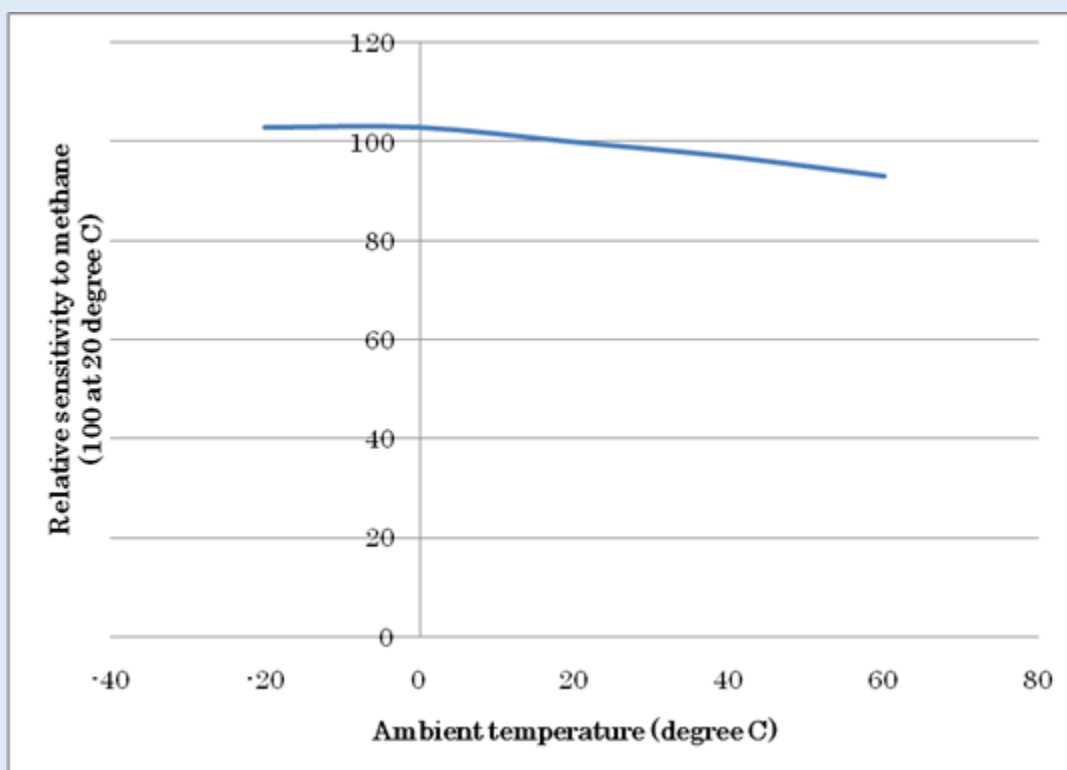



Humidity Dependence

Typical Zero Offset Drift with Humidity

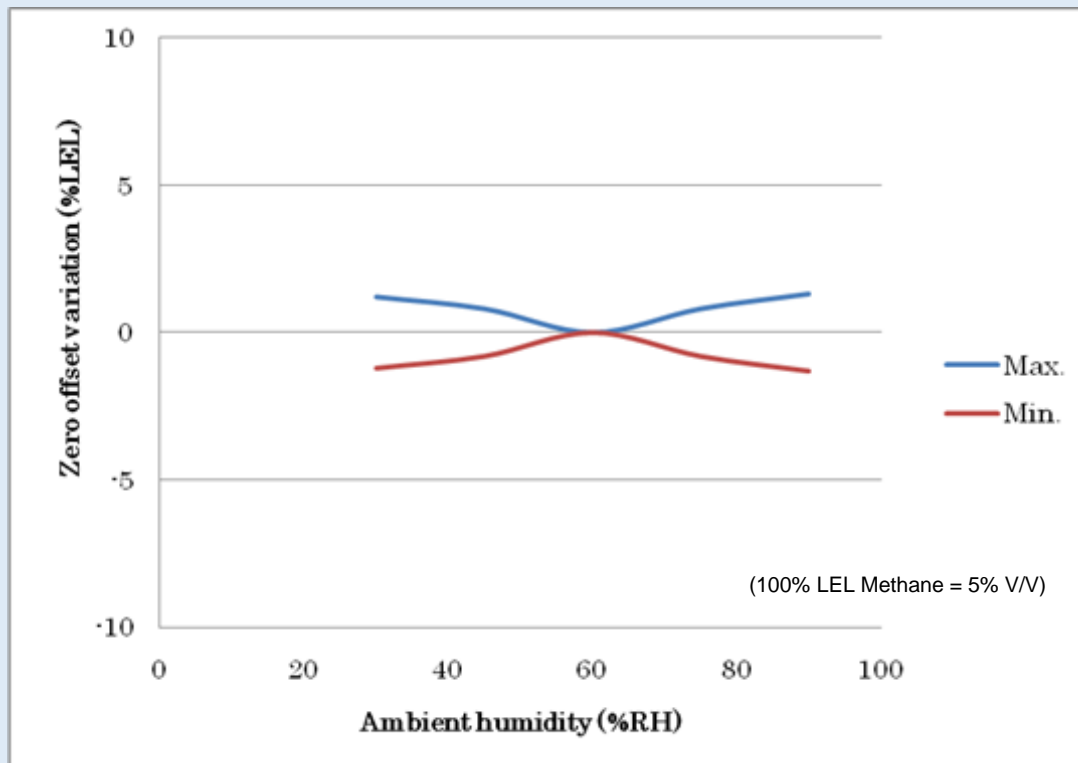

Typical Gas Sensitivity Drift with Humidity

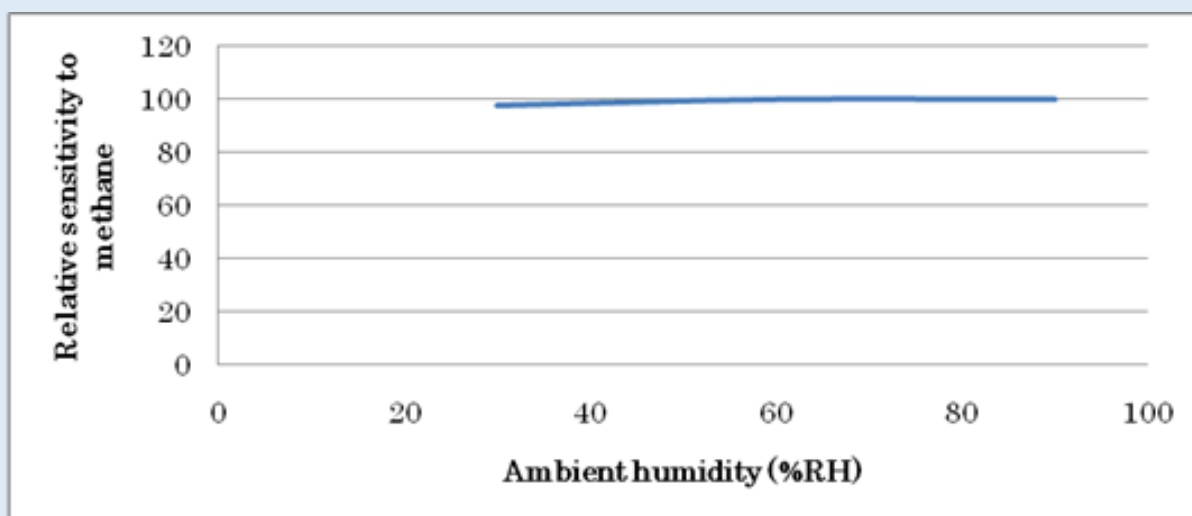



Relative Responses to various gases

Below is a table of the NCP-180S-7S responses to various flammable gases. The table assumes the sensor is measuring on the 0-100% LEL scale and assumes that the response to methane = 100%.

Note that the LEL data can be different in different countries. In Europe, the LEL's used are defined in the IEC standard IEC80079-20-1, whilst in the USA and various other areas, LELs are generally taken from the US Bureau of Mines Bulletin Document 627.

Technically, both are correct; the reason for the differences being that the measurements made for IEC80079-20-1 are with the gas in motion, whilst the US Bureau of Mines Bulletin Document 627 assumes the gas is not moving.

For convenience, relative responses are given according to BOTH standards below.

Gas	Formula	LEL Europe (IEC80079-20-1)	Relative response (%)	LEL (USA) (USBoM 627)	Relative response (%)
Methane	CH₄	4.4	100	5	100
Acetone	(CH ₃) ₂ CO	2.5	22	2.6	20
Ethanol	C ₂ H ₅ OH	3.1	27	3.3	26
Ethyl acetate	C ₂ H ₅ COOCH ₃	2	22	2.2	21
Ethylene	C ₂ H ₄	2.3	56	2.7	58
Hydrogen	H ₂	4	97	4	85
Iso-propanol	CH ₃ CH(OH)CH ₃	2	19	2.2	18
Methanol	CH ₃ OH	6	46	6.7	46
n-Butane	C ₄ H ₁₀	1.4	47	1.8	53
n-Heptane	C ₇ H ₁₆	0.85	40	1.05	43
n-Hexane	C ₆ H ₁₄	1	42	1.2	44
n-Pentane	C ₅ H ₁₂	1.1	41	1.4	46
Propane	C ₃ H ₈	1.7	54	2.1	59
Toluene	C ₆ H ₅ CH ₃	1	24	1.2	25
Propylene	CH ₃ -CH=CH ₂	2	74	2.4	78
Cyclo-hexane	C ₆ H ₁₂	1	44	1.3	50
Cyclo-pentane	C ₅ H ₁₀	1.4	63	1.5	59
Iso-butane	C ₄ H ₁₀	1.3	46	1.8	56
Iso-octane	C ₈ H ₁₈	0.7	36	not given	32
n-octane	CH ₃ (CH ₂) ₆ CH ₃	0.8	40	0.95	42
Styrene	C ₆ H ₅ CH=CH ₂	1	14	1.1	14
Xylene	C ₆ H ₄ (CH ₃) ₂	1	26	1.1	25
Carbon monoxide	CO	10.9	42	12.5	42
Ammonia	NH ₃	15	68	15	60

For other flammable gases, Nemoto can advise on the anticipated sensitivity of the sensor. Since the relative sensitivities to various gases is also dependent on the mounting arrangement within an instrument, this data should always be considered as a guide only - it is always recommended that the instrument maker determines the response of the sensor to the target gas by experiment using the final product design wherever possible.



Silicone Poison Resistance

The plot below represents the typical response to exposure to 100ppm HMDS (HexaMethylDiSiloxane) in the presence of 50% LEL (2.5%) Methane. The initial sensitivity was measured at 200 seconds and assumed to represent 100%

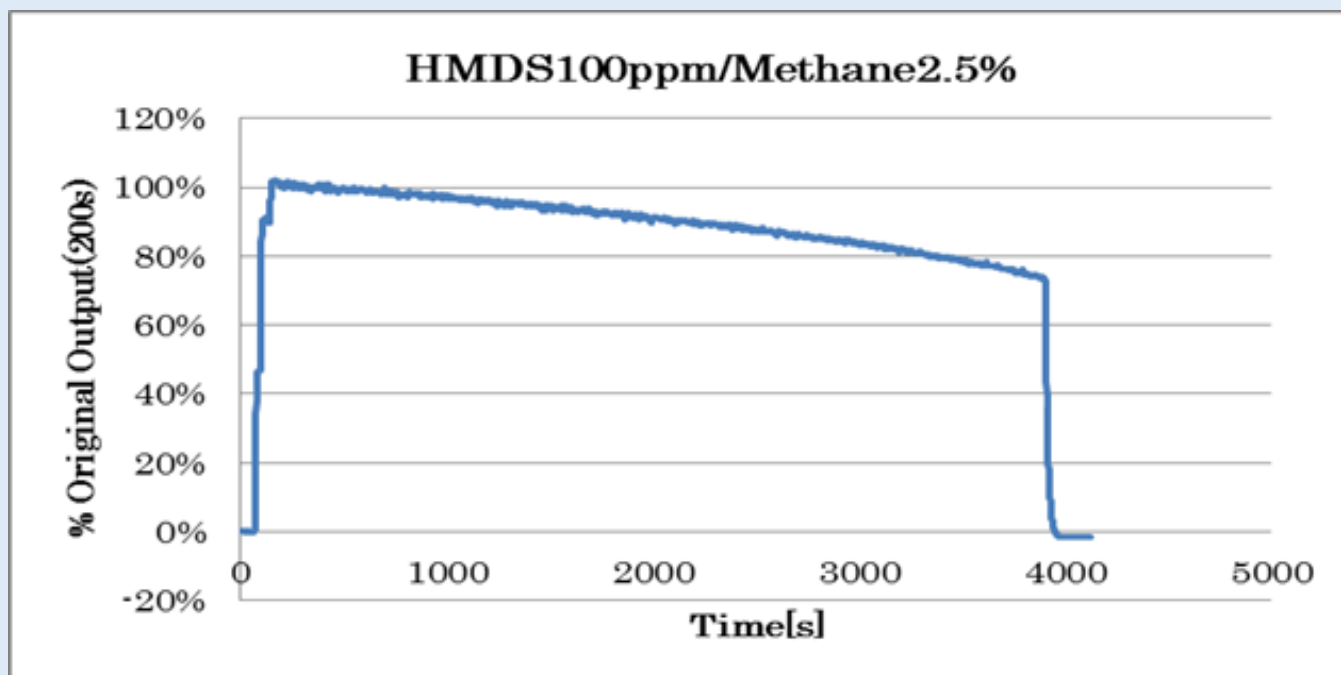

Recovery from Silicone Poisoning

An unusual (perhaps unique) feature of Nemoto Catalytic Pellistor Gas Sensors is their ability to partially recover from poisoning by Silicone vapours. The sensors used in the test above were allowed to settle for 24 hours, and their sensitivity to methane was re-measured. The average sensitivity of the sensors was observed to be 91% of the original sensitivity.



Exposure to overrange Conditions

Sensors were exposed in 8% Methane at normal temperature and humidity for 1 hour.

No.	Before test (mV)		After test (mV)	
	Zero offset	Relative sensitivity to CH ₄	Zero offset	Relative sensitivity to CH ₄
1	3.2	100	2.7	100
2	-11.2	100	-10.4	98
3	-0.6	100	0.2	98
4	3.2	100	3.8	98
5	16.4	100	17.1	97

Shock

Sensors were dropped from the height of 30cm onto the wood board of 3 cm thickness with free fall. The drop was repeated 3 times.

No.	Before test (mV)		After test (mV)	
	Zero offset	Relative sensitivity to CH ₄	Zero offset	Relative sensitivity to CH ₄
1	1.9	100	1.5	100
2	7.3	100	6.8	101
3	10.2	100	9.7	100
4	-2.7	100	-3.2	100
5	10.7	100	10.1	102

Vibration

A vibration of 10Hz with 4mm amplitude in all 3 directions of X, Y and Z, was applied to the sensors for 20 minutes.

No.	Before test (mV)		After test (mV)	
	Zero offset	Relative sensitivity to CH ₄	Zero offset	Relative sensitivity to CH ₄
1	21.4	100	21.8	100
2	9.6	100	9.8	101
3	-13.7	100	12.9	100
4	6.5	100	5.9	100
5	7.7	100	8.1	100



Storage in high temperature and humidity

Sensors were stored unpowered in 60 degree C, 90%RH for 1000 hours.

No.	Before test (mV)		After test (mV)	
	Zero offset	Relative sensitivity to CH ₄	Zero offset	Relative sensitivity to CH ₄
1	-5.6	100	-6.1	100
2	7.7	100	8.0	100
3	10.1	100	9.7	99
4	9.6	100	10.2	102
5	3.8	100	4.4	99

Operation in high temperature and humidity

Sensors were energized in 60 degree C, 90%RH for 1000 hours.

No.	Before test (mV)		After test (mV)	
	Zero offset	Relative sensitivity to CH ₄	Zero offset	Relative sensitivity to CH ₄
1	5.9	100	6.3	98
2	0.3	100	1.0	97
3	12.8	100	12.9	97
4	17.5	100	17.1	97
5	11.3	100	10.8	95

Storage in low temperatures

Sensors were stored at -20 degree C for 1000 hours

No.	Before test (mV)		After test (mV)	
	Zero offset	Relative sensitivity to CH ₄	Zero offset	Relative sensitivity to CH ₄
1	5.1	100	4.9	97
2	10.3	100	10.4	101
3	11.9	100	11.1	94
4	-14.5	100	-14.7	97
5	12.2	100	11.8	100



Notes on sensor testing

All Nemoto specifications are based on testing within a gas filled chamber. Testing the sensor using a flow-through system will yield similar, but not identical, results. The Nemoto test set up is illustrated below:

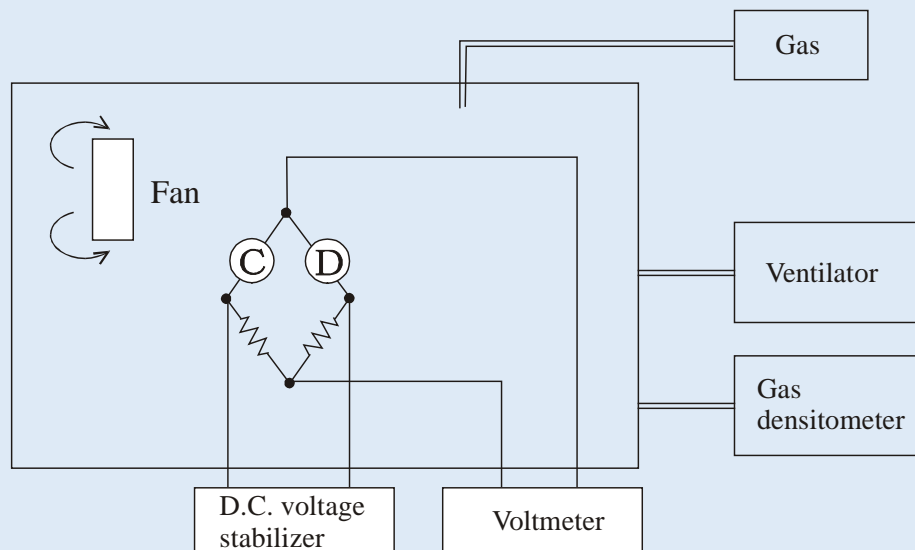

The test chamber should be constructed of glass, or another material known not to absorb gases.

In Nemoto's test regime, test gases are introduced into the chamber by injection, following careful calculation of the amount of gas required to generate the required concentration within the chamber. This may also be accomplished by purging the chamber using gas from a test gas cylinder, provided the flow rate used is not high enough to cause turbulence in the chamber.

The gas inside the chamber should be gently agitated by a slow moving fan, to ensure that concentration gradients do not develop during testing, either by stratification layers forming in the chamber, or by the consumption of the gas by the sensors themselves.