



TECHNICAL INFORMATION SHEET

NAP-66A Catalytic Gas Sensor, Optimised for the Detection of LPG, Butane, Propane

Nemoto & Co., Ltd.
Sensor Division
4-10-9, Takaido-higashi,
Suginami-ku, Tokyo,
JAPAN

General Description

The NAP-66A Gas Sensor is a low-cost Catalytic Flammable Gas Sensor designed for the detection and measurement of Propane, Butane, and LPG vapours in the range 0-50% LEL.

Developed primarily for use in Residential Gas Detectors, the NAP-66A has also been found to be useful in a wide variety of applications where reliable detection of gas or fuel leaks and other gas hazards is required at low cost.

The NAP-66A uses the superior catalytic "pellistor" detection principle often used in high quality Industrial Gas Detectors. It hence has many benefits over other low cost gas sensor types.



- **Monitors flammability directly**
- **Unaffected by humidity**
- **Very low long term drift**
- **Excellent resistance to catalytic poisons**
- **Single header design for ease of use**
- **Superb temperature stability**
- **Resistant to shocks and vibration**
- **Linear output to 50% LEL**

Specifications:

Detectable Gas	Propane/Butane/LPG
Recommended Voltage:	2.0V +/- 0.2V
Current Drawn:	150 +/- 10mA
Zero Offset:	0mV +/- 35mV
Signal Sensitivity:	16mV @2000ppm C4H10
Range:	0-60% LEL
Repeatability:	+/- 0.5mV
Maximum Long Term Drift:	
Span:	< +/- 2% Signal / Month
Zero:	< +/- 5 mV/Month
Response Time:	T ₉₀ : <10 sec
Temperature Range:	-20°C to +60°C
Humidity:	0-95%RH, non-condensing
Linearity:	Effectively Linear to 60%LEL
Expected Lifetime	5 years

Test data on drift, poisoning, temperature performance, linearity are available on the Characterisation Document.

Nemoto has a policy of continuous development and improvement of its products. As such the specification for the device outlined in the data sheet may be changed without notice

nap-66a.ppp, issue 4, February 2022

Contact Information:

Europe & Africa Area

Asia Area

Americas Area

Website

www.nemoto.eu

www.nemoto.co.jp

www.nemoto.eu

email

eusensor@nemoto.co.jp

sensor2@nemoto.co.jp

nasensor@nemoto.co.jp

Telephone

+44 (0)1799 543968

+81 3 3333 2760

+1 604 761 7363

Dimensions, Materials and Recommended Circuit

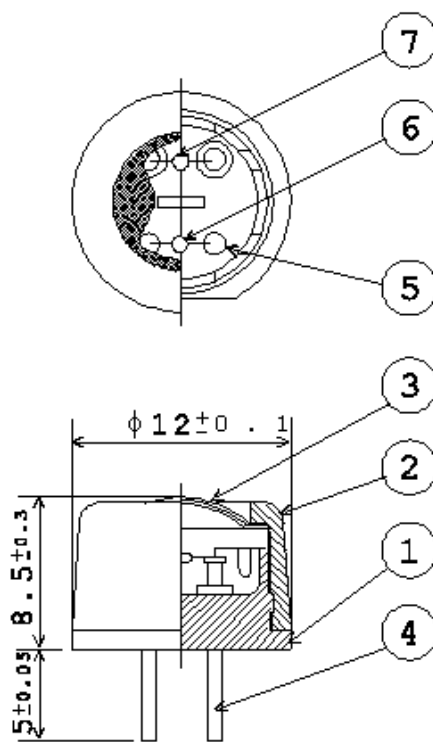

Detector mark

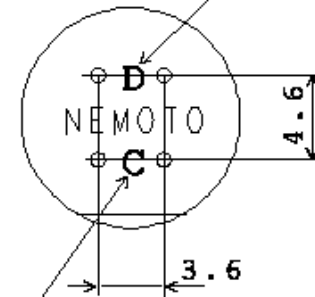

Compensator mark

Bottom view

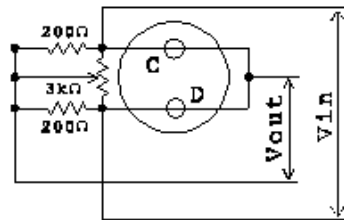

Measuring circuit

7	Detector	_____	NEMOTO & CO., LTD.
6	Compensator	_____	NEMOTO & CO., LTD.
5	Coil	Pt	$\phi 30 \mu\text{m}$
4	Pin	Pure Ni	$\phi 0.8$
3	Strainer	808316 $\phi 100 \text{ mesh}$	Double layered
2	Cap	66Nylon	20% Glass
1	Base mount	66Nylon	20% Glass
No.	PARTS	MATERIALS	REMARKS

	APPROVED	CHECKED	DESIGNED	DRAWN	MATERIAL	Q.TY	SCALE
					DATE	DRG. NO.	
					DEC, 25, 1999	G-01-04-143	
THIRD ANGLE PROJECTION	TITLE				NEMOTO & CO., LTD.		
	NAP-66A						

Test data on drift, poisoning, temperature performance, linearity are available on the Characterisation Document.

Nemoto has a policy of continuous development and improvement of its products. As such the specification for the device outlined in the data sheet may be changed without notice

Nap-66a.ppp, issue 4, February 2022

Contact Information:

Europe & Africa Area

Asia Area

Americas Area

Website

www.nemoto.eu

www.nemoto.co.jp

www.nemoto.eu

email

eusensor@nemoto.co.jp

sensor2@nemoto.co.jp

nasensor@nemoto.co.jp

Telephone

+44 (0)1799 543968

+81 3 3333 2760

+1 604 761 7363