	<p style="text-align: center;">Nemoto Sensor Engineering Company Ltd</p>	<p>4-10-9 Takaido-Higashi Suginami-ku Tokyo 168-0072, Japan</p> <p style="text-align: right;">www.nemoto.eu</p>
---	---	--

NCP-180S Explosive/Flammable Gas Sensor Operating Characteristics and Handling Manual



The NCP-180S is a Catalytic (pellistor) type flammable gas sensor supplied as a matched pair of pellistor elements mounted on a single header and protected by a metal header and gauze.

The sensor detects and measures the presence of flammable gases and vapours in air, in the range 0-60%* of the Lower Explosive Limit (LEL) of the gas or vapour being measured. The sensor is designed for use in a wide range of Fixed Gas Detection Systems.

The NCP-180S exhibits excellent long term zero and sensitivity stability and a high level of resistance to catalytic poisons. The highly automated manufacturing procedure employed by Nemoto results in a repeatable, reliable sensor which, unlike similar devices, requires no trimming resistor to enable the detector to be matched with a compensator.



Contents

Principles of Operation.....	3
General Specifications.....	4
Outline Drawing and construction.....	5
Performance Measurements.....	6
Gas Sensitivity/Linearity.....	6
Temperature Dependence.....	6
Humidity Dependence.....	7
Sensitivity Distribution.....	8
Relative Responses to Various Gases.....	9
Poison Resistance.....	10
Exposure to Overrange Conditions.....	11
Shock and Vibration resistance.....	11
Storage and Operation in extreme Environmental Conditions.....	12
Notes on Sensor Testing.....	13

Nemoto Sensor Engineering Company Ltd
168-0072 4-10-9, Takaido-higashi, Suginami-ku, Tokyo
TEL. 81-3-3333-7341
FAX. 81-3-3333-7344
WEB: <http://www.nemoto.eu>

Note that the Performance measurements expressed in this document should be considered as typical characteristics for guidance only, and not as specifications which are guaranteed, apart from those in the sections "General Specifications" and "Dimensions" (Pages 4 and 5). It is the instrument designer's responsibility to ensure that the sensor is suitable for any given application.

Nemoto has a policy of continuous development and improvement of its products. As such the specification for the device outlined in this document may be changed without notice.

NCP-180S-manual.docx
Issue 4, January 2021



Principles of Operation:

Catalytic combustion has been the most widely used method of detecting flammable gases in Industry since the invention of the catalysed pelletized resistor (or "Pellistor") over 40 years ago.

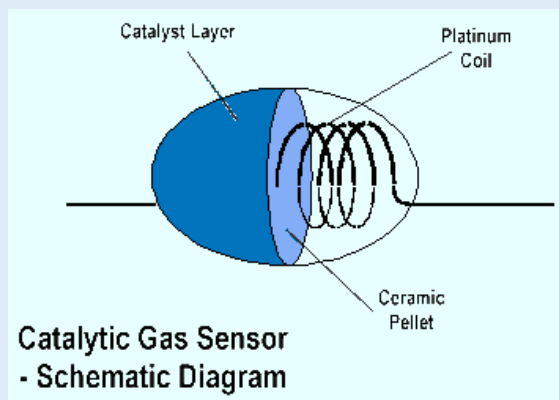

A Pellistor consists of a very fine coil of platinum wire, embedded within a ceramic pellet. On the surface of the pellet is a layer of a high surface area noble metal, which, when hot, acts as a catalyst to promote exothermic oxidation of flammable gases. In operation, the pellet and so the catalyst layer is heated by passing a current through the underlying coil. In the presence of a flammable gas or vapour, the hot catalyst allows oxidation to occur in a similar chemical reaction to combustion. Just as in combustion, the reaction releases heat, which causes the temperature of the catalyst together with its underlying pellet and coil to rise. This rise in temperature results in a change in the electrical resistance of the coil, and it is this change in electrical resistance which constitutes the signal from the sensor.

Pellistors are always manufactured in pairs, the active catalysed element being supplied with an electrically matched element which contains no catalyst and is treated to ensure no flammable gas will oxidise on its surface. This "compensator" element is used as a reference resistance to which the sensor's signal is compared, to remove the effects of environmental factors other than the presence of a flammable gas.

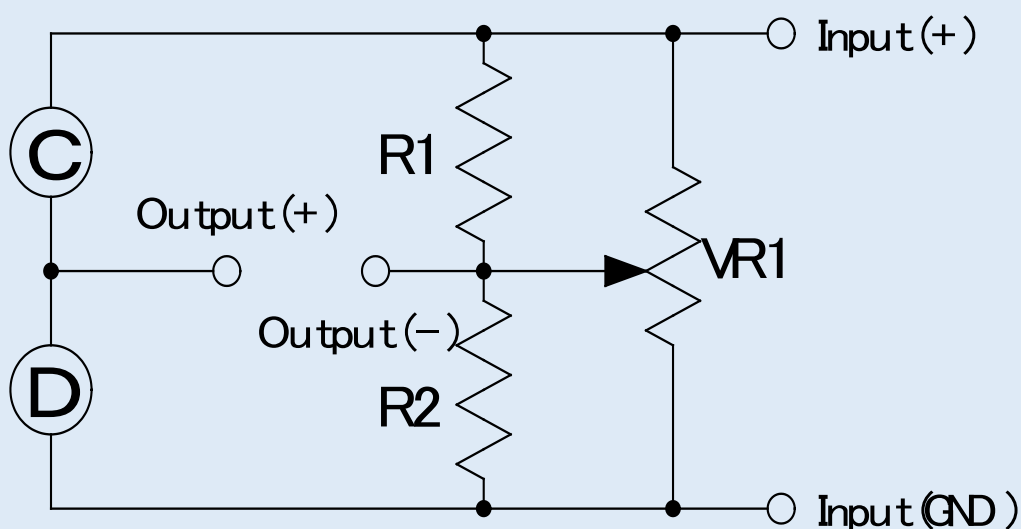

Pellistor Drive/Measurement Circuit: A simple Wheatstone Bridge to compare the resistance of two hot elements



The advantage of using this technique when detecting flammable gases for safety purposes is that it measures flammability directly.

Nemoto provides matched pair Pellistors conveniently mounted in a variety of enclosures for different applications. Some of these options contain the detector and compensator elements in separate enclosures (the NP range for Industrial applications). In the case of the NCP-180S, both elements are contained within a plastic enclosure for ease of use and low cost.

Catalytic pellistor type gas sensors have many advantages compared with semiconductor type gas sensors

- ❖ Linear output in proportion to gas concentration
- ❖ Greater Stability
- ❖ Higher reproducibility
- ❖ Gas specific - will only respond to flammable gases
- ❖ Unaffected by humidity
- ❖ Stable output for long periods
- ❖ More resistant to shocks and vibrations.

General Specifications:

Operating Specifications:	
Detected Gases	Flammable Gases (Specifications are based on the detection of Methane/Natural Gas)
Standard Concentration Range	0-50% LEL
Recommended Bridge Voltage	2.6V +/- 0.1V
Current Consumption (at Recommended Bridge Voltage)	170mA +/- 25mA
Bridge zero offset	0 +/- 30mV
Minimum Output Sensitivity	60 mV for 1% CH₄
Linearity	Effectively Linear to 50% LEL
Response Time (Measured as T90)	<8secs
Accuracy (Measured as Repeatability)	± 0.5mV for Zero ± 1% LEL for Gas Sensitivity
Long Term Stability Drift	Sensitivity: Less than +/- 1% signal / month Zero: Less than +/- 0.5mV / month
Expected Lifetime in the field	> 3 Years.
Warranty Period	24 Months
Environmental Specifications:	
Temperature Range	-30°C to +60°C
Standard constant Humidity Range	0 to 95%RH
Standard Constant Pressure Range	1atm ± 10%
Recommended storage Temperature Range	0 to 20 degree C
Recommended Maximum Storage Time	6 months
Mechanical Data	
Enclosure Material	Nickel Plated Brass
Connector Pin Material	Nickel



Appearance and Dimensions

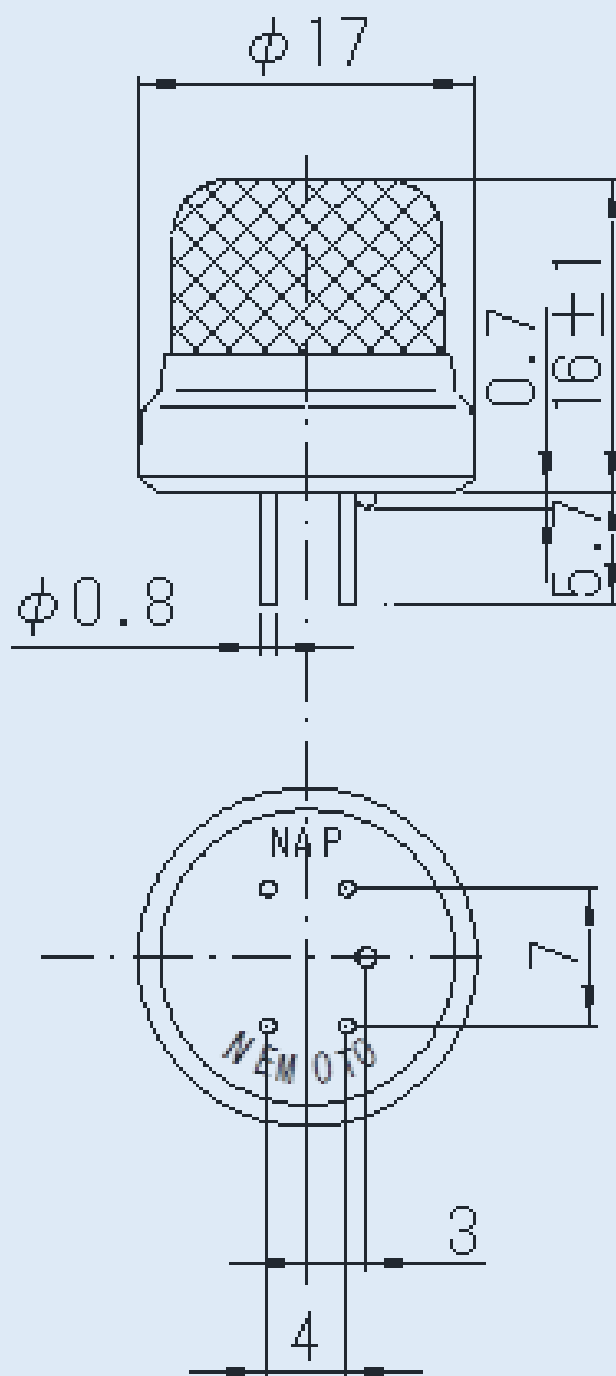

(± 0.2)

All Dimensions in mm
Tolerances +/- 0.2mm



Performance Measurements

Gas sensitivity / Linearity

The graph below shows the typical sensitivity characteristics for methane. One can see that the sensor is not 100% linear (as with all pellistor gas sensors), but the deviation from linearity is very small and can be compensated for in software if required. More details on linearity can be supplied on request.

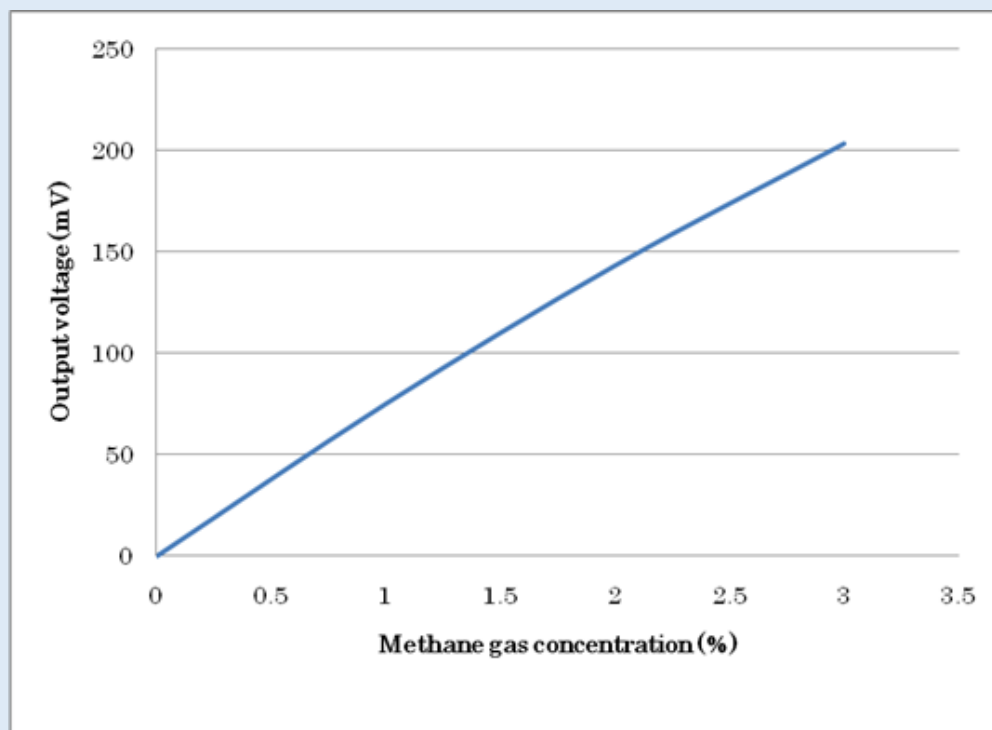

Temperature Dependence

Typical Zero Offset Drift with Temperature

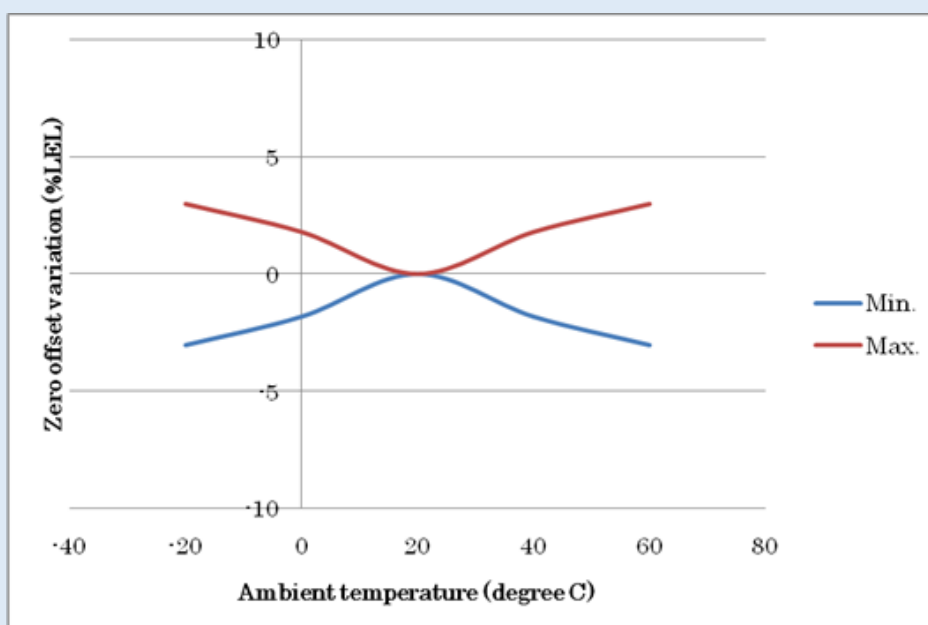



Typical Gas Sensitivity Drift with Temperature

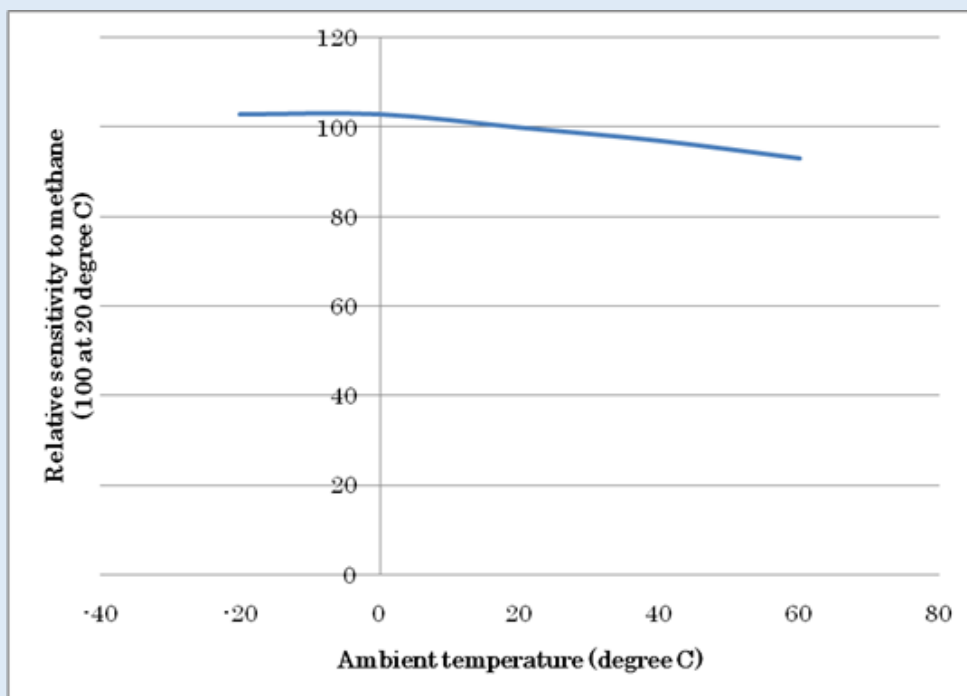

Humidity Dependence

Typical Zero Offset Drift with Humidity

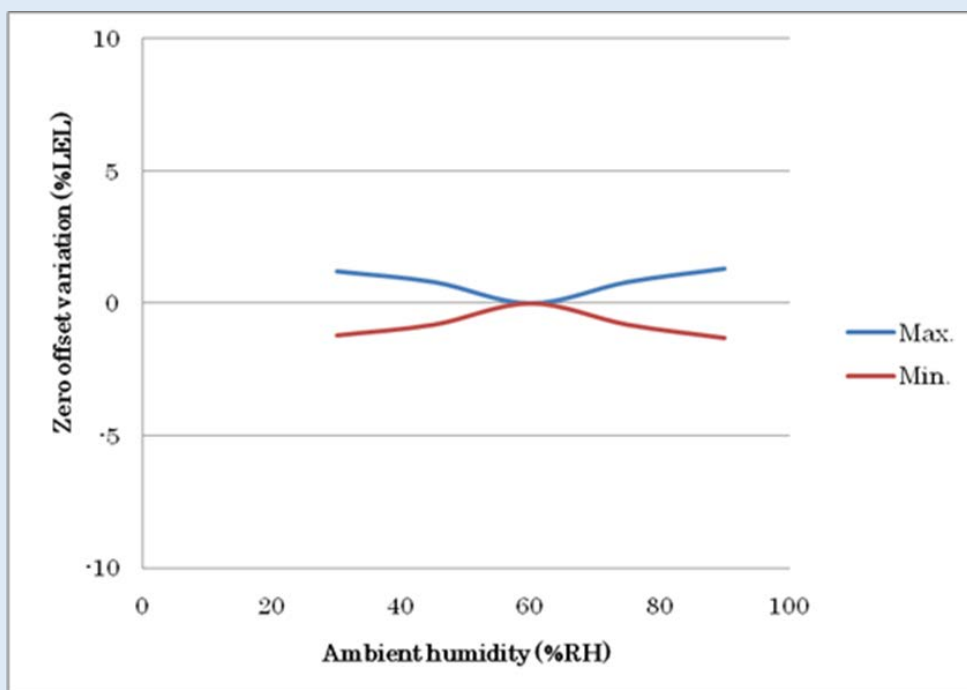



Typical Gas Sensitivity Drift with Humidity

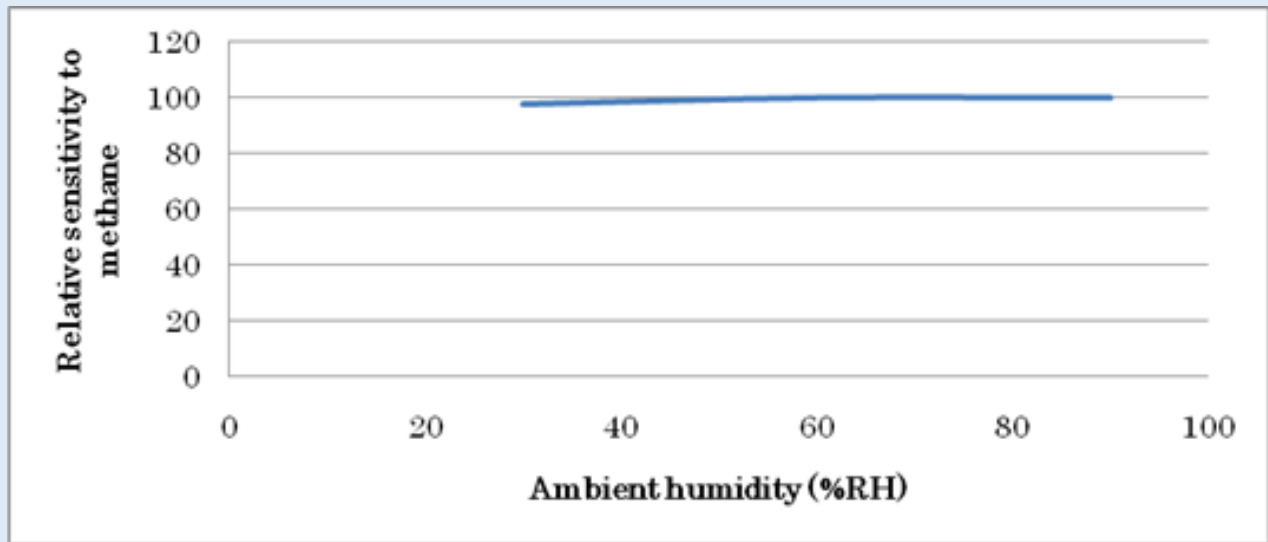

Sensitivity distribution

The below plot gives a distribution of sensitivities for 300 randomly selected sensors.

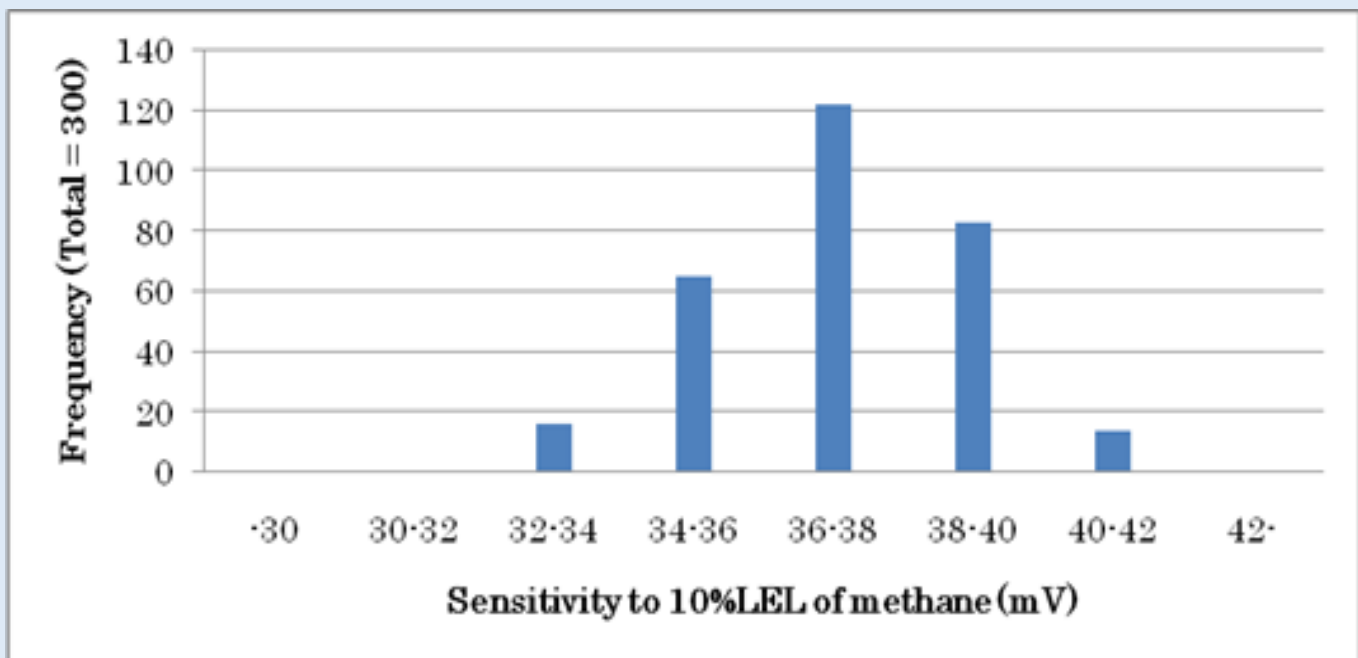



Relative Responses to various gases

Below is a table of the NCP-180S responses to various flammable gases. The table assumes the sensor is measuring on the 0-100% LEL scale and assumes that the response to methane = 100%.

Note that the LEL data can be different in different countries. In Europe, the LEL's used are defined in the IEC standard IEC80079-20-1, whilst in the USA and various other areas, LELs are generally taken from the US Bureau of Mines Bulletin Document 627.

Technically, both are correct; the reason for the differences being that the measurements made for IEC80079-20-1 are with the gas in motion, whilst the US Bureau of Mines Bulletin Document 627 assumes the gas is not moving.

For convenience, relative responses are given according to BOTH standards below.

Gas	Formula	LEL (Europe) (IEC80079-20-1)	Relative response (%)	LEL (USA) (USBoM 627)	Relative response (%)
Methane	CH₄	4.4	100	5	100
Acetic acid	CH ₃ COOH	4	11	5.4	14
Acetone	(CH ₃) ₂ CO	2.5	51	2.6	47
Cyclo-hexane	C ₆ H ₁₂	1	52	1.3	60
Cyclo-pentane	C ₅ H ₁₀	1.4	68	1.5	64
Ethanol	C ₂ H ₅ OH	3.1	55	3.3	52
Ethyl acetate	C ₂ H ₅ COOH	2	49	2.2	47
Ethylene	C ₂ H ₄	2.3	77	2.7	80
Hydrogen	H ₂	4	119	4	105
Iso-butane	C ₄ H ₁₀	1.3	53	1.8	65
Iso-octane	C ₈ H ₁₈	0.7	40	Not Given	40
Iso-propanol	CH ₃ -C ₂ H ₄ COOH	2	34	2.2	33
Methanol	CH ₃ OH	6	74	6.7	73
N-butane	C ₄ H ₁₀	1.4	60	1.8	68
n-Heptane	C ₇ H ₁₆	0.85	48	1.05	53
n-Hexane	C ₆ H ₁₄	1	52	1.2	55
n-Pentane	C ₅ H ₁₂	1.1	54	1.4	61
Propane	C ₃ H ₈	1.7	64	2.1	70
Styrene	C ₆ H ₅ CH=CH ₂	1	36	1.1	35
Toluene	C ₆ H ₅ CH ₃	1	47	1.2	50
Ammonia	NH ₃	15	97	15	85
Propylene	CH ₃ -CH=CH ₂	2	80	2.4	84
Carbon monoxide	CO	10.9	74	12.5	75
Xylene	C ₆ H ₄ (CH ₃) ₂	1	52	1.1	50
n-Octane	CH ₃ (CH ₂) ₆ CH ₃	0.8	45	0.95	48

For other flammable gases, Nemoto can advise on the anticipated sensitivity of the sensor. Since the relative sensitivities to various gases is also dependent on the mounting arrangement within an instrument, this data should always be considered as a guide only - it is always recommended that the instrument maker determines the response of the sensor to the target gas by experiment using the final product design wherever possible.



Poison Resistance

Hydrogen Sulphide (H₂S)

Sensors were exposed in 50%LEL Methane and 25ppm Hydrogen Sulphide for 1 hour. at normal temperature and humidity.

No.	Before test (mV)		After test (mV)	
	Zero offset	Relative sensitivity to CH ₄	Zero offset	Relative sensitivity to CH ₄
1	18.9	100	20.0	100
2	10.7	100	11.8	96
3	7.5	100	8.8	90
4	20.8	100	22.5	98
5	-7.4	100	-5.6	97

Silicones

Sensors were exposed in 50%LEL of methane and 10ppm of HMDS (HexaMethylDiSiloxane) for 1 hour. at normal temperature and humidity.

No.	Before test (mV)		After test (mV)	
	Zero offset	Relative sensitivity to CH ₄	Zero offset	Relative sensitivity to CH ₄
1	0.5	100	1.8	60
2	27.5	100	27.8	57
3	-12.3	100	-12.4	72
4	1.9	100	2.8	75
5	3.7	100	4.5	64

Exposure to overrange Conditions

Sensors were exposed in 8% (160%LEL) methane at normal temperature and humidity for 1 hour.

No.	Before test (mV)		After test (mV)	
	Zero offset	Relative sensitivity to CH ₄	Zero offset	Relative sensitivity to CH ₄
1	25.2	100	27.0	102
2	17.2	100	18.4	96
3	24.6	100	25.8	97
4	5.4	100	7.1	97
5	8.0	100	8.8	99



Shock

Sensors were dropped from the height of 30cm onto the wood board of 3 cm thickness with free fall. The drop was repeated 3 times.

No.	Before test (mV)		After test (mV)	
	Zero offset	Relative sensitivity to CH4	Zero offset	Relative sensitivity to CH4
1	16.9	100	17.2	100
2	-26.4	100	-26.7	100
3	-11.3	100	-11.9	100
4	4.5	100	5.1	99
5	17.1	100	17.1	101

Vibration

A vibration of 10Hz with 4mm amplitude in all 3 directions of X, Y and Z, was applied to the sensors for 20 minutes.

No.	Before test (mV)		After test (mV)	
	Zero offset	Relative sensitivity to CH4	Zero offset	Relative sensitivity to CH4
1	1.8	100	1.7	98
2	7.9	100	8.8	102
3	7.2	100	8.0	102
4	21.7	100	21.4	100
5	19.6	100	18.8	102

Storage in high temperature and humidity

Sensors were stored unpowered in 60 degree C, 90%RH for 1000 hours.

No.	Before test (mV)		After test (mV)	
	Zero offset	Relative sensitivity to CH4	Zero offset	Relative sensitivity to CH4
1	15.3	100	16.2	100
2	11.1	100	12.3	97
3	17.2	100	18.5	95
4	-23.9	100	-23.8	99
5	-22.4	100	-22.4	99



Operation at high temperature and humidity

Sensors were energized in 60 degree C, 90%RH for 1000 hours.

No.	Before test (mV)		After test (mV)	
	Zero offset	Relative sensitivity to CH4	Zero offset	Relative sensitivity to CH4
1	2.7	100	2.5	99
2	1.1	100	1.7	96
3	6.5	100	8.6	96
4	-11.8	100	-10.5	100
5	6.8	100	7.0	94

Storage at low temperatures

Sensors were stored at -20 degree C for 1000 hours

No.	Before test (mV)		After test (mV)	
	Zero offset	Relative sensitivity to CH4	Zero offset	Relative sensitivity to CH4
1	24.5	100	24.1	98
2	13.4	100	14.4	100
3	-29.6	100	-28.1	95
4	12.7	100	13.5	93
5	5.6	100	6.2	98



Notes on sensor testing

All Nemoto specifications are based on testing within a gas filled chamber. Testing the sensor using a flow-through system will yield similar, but not identical, results. The Nemoto test set up is illustrated below:

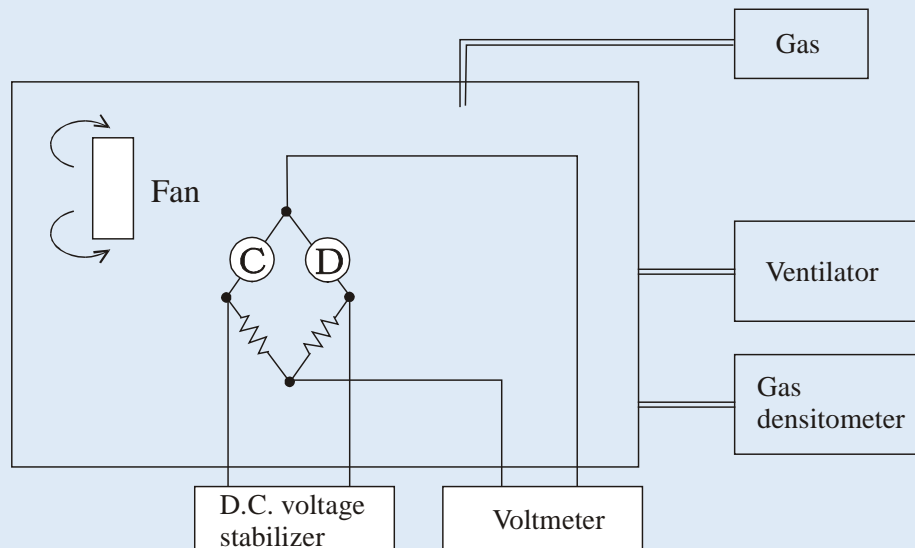

The test chamber should be constructed of glass, or another material known not to absorb gases.

In Nemoto's test regime, test gases are introduced into the chamber by injection, following careful calculation of the amount of gas required to generate the required concentration within the chamber. This may also be accomplished by purging the chamber using gas from a test gas cylinder, provided the flow rate used is not high enough to cause turbulence in the chamber.

The gas inside the chamber should be gently agitated by a slow moving fan, to ensure that concentration gradients do not develop during testing, either by stratification layers forming in the chamber, or by the consumption of the gas by the sensors themselves.