



**Nemoto & Co.,Ltd.
Sensor Division**

4-10-9 Takaido-Higashi
Suginami-ku
Tokyo 168-0072,
Japan

www.nemoto.eu

Operating Characteristics and Handling Manual for the NAP-550 Nitrogen Dioxide (NO₂) Gas Sensor



Nemoto has a policy of continuous development and improvement of its products. As such the specification for the device outlined in this document may be changed without notice.



INTRODUCTION

Nemoto & Co. Ltd was established in 1941 and continues to develop unique technologies for Safety, Security and Health markets worldwide. Using our unique experience of fine chemical preparation and printing, we were able to enter the gas sensor market in 1979 with a range of high-quality hot-wire type sensors (pellistors). Nemoto is now one of the world's leading manufacturers of chemical sensors and has so far delivered over 30-million devices to the market.

As a result of three years' development at our Tokyo R&D centre, we released our first electrochemical gas sensor in 2000.

The NAP-550 Gas Sensor is a 3-Electrode electrochemical gas sensor designed for the detection and measurement of nitrogen dioxide (NO₂) in the range 0-30 ppm, in a wide range of industrial and commercial safety applications. By adhering to industry standards for size and connection orientation, the NAP-550 can be retrofitted easily to existing product designs.

The sensor is especially designed to complement the popular NAP-505 Carbon monoxide (CO) gas sensor, when used together in underground carpark monitoring systems, but it may also be used in a wide variety of other applications when reliable detection and monitoring of NO₂ is required at low-cost.

By using our experience of design for manufacture and our high volume production facilities in Japan and China, we have successfully reduced the cost of the NAP-550 whilst being able to maintain the highest performance quality.

PRINCIPLES OF OPERATION

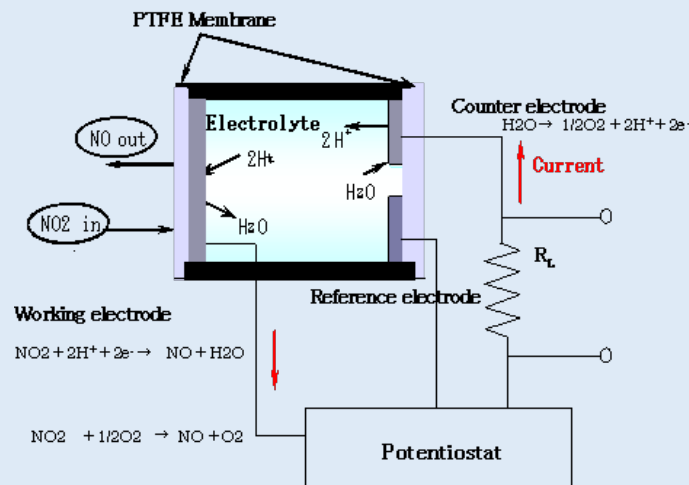

The NAP-550 consists of 3 porous noble metal electrodes separated by an acidic aqueous electrolyte, housed within a plastic (PPO) enclosure. An electrolyte reservoir ensures an excess of electrolyte is available at all times, and the sensor is vented to ensure that the internal and external pressure of the sensor is always in equilibrium.



In operation, gas enters the cell via the capillary and filter, and comes into contact with the ‘working’ electrode. Any nitrogen dioxide present undergoes the following (reduction) reaction:

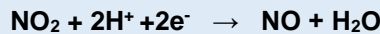

The NO generated vents away from the cell via the capillary, whilst the hydrogen ions (H⁺) are supplied by the electrolyte within the cell. The electrons (e⁻) are supplied by the external circuit via a metal strip in contact with it, in the form of a small (nA) electric current.

The reaction at the working electrode is balanced by a reciprocal (oxidation) reaction at the ‘counter’ electrode, using water from the electrolyte:

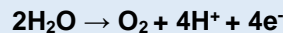

The electrons generated in this reaction are removed by the external circuit via a metal strip in contact with the counter electrode.

Thus when Nitrogen Dioxide is present, water is generated whilst Hydrogen ions are consumed at the working electrode, whilst the water is re-used and hydrogen ions are generated at the counter electrode. At the same time, the reaction at the working electrode consumes electrons, whilst the reaction at the counter electrode generates electrons. By connecting the working and counter electrodes together via a special circuit, the flow of electrons between the two electrodes may be measured as a nA level current signal proportional to the ppm concentration of nitrogen dioxide.

The ‘reference’ electrode maintains the healthy operation of the cell. It is surrounded by electrolyte, sees no gas and no current is allowed to be drawn from it. Its electrochemical potential hence always remains constant at a level known as the “rest air potential” and this is used to regulate the potential of the working electrode, regardless of the current it is generating during operation. The use of a reference electrode in this way (i.e. three-electrode operation) helps to extend the working range of the sensor, improves linearity and results in a number of performance benefits compared with similar sensors working with 2-electrodes only.

Features

The NAP-550 has been developed from our accumulation of technologies in production of hot-wire type gas sensors, long research experience into catalysts, fine printing, and assembling of sensors. The NAP-550 is small and less-expensive, but has high sensitivity, long life, and leak-free performance even under severe operating conditions.

Small-size: The NAP 550 is one of the smallest electrochemical sensors in the world to accommodate the design and manufacture of smaller gas detection products and allowing space for additional features.

Air vent: The electrolyte used for chemical sensors is hygroscopic, i.e. it has affinity for water, and its volume varies depending on ambient temperature and humidity. This variation causes pressure inside the sensor to rise and fall. In the worst case the electrolyte may leak out of the sensor and damage the circuitry around it.

To prevent this, the NAP-550 combines small size with an air vent capability. This maintains equilibrium between internal and external pressures and allows the sensor to be used in any orientation and under high temperature and humidity conditions.

Solderable: Conventional electrochemical sensors cannot be soldered directly to pins because the rapid temperature increase causes thermal deformation of the plastic housing and subsequent leakage of electrolyte. The NAP-505 uses a unique electrode pin and socket design to dissipate heat and minimize the effect of high temperature. This simplifies the assembling process as the NAP-550 can be soldered directly to a PCB (see notes on page 29).



General Specifications:

Operating Specifications:	
Detected Gas	Nitrogen Dioxide, NO ₂
Standard concentration range	0 – 30 ppm
Output Sensitivity	150nA ± 30nA/ppm
Zero Offset at 20°C	< +/- 0.5ppm equivalent
Minimum Detectable Limit	0.2 ppm
Response Time (Measured as T90T)	<25 secs
Accuracy (Measured as Repeatability)	± 2%of Signal
Temperature Dependence (Zero)	± 2 ppm between -20°C and +50°C
Long Term Sensitivity Drift	Less than +/- 4% FSD per year
Expected Lifetime in the field	< 2 Years
Environmental Specifications:	
Temperature Range	-20 to +50 degree C
Standard constant Humidity Range	15 to 90%RH, non-condensing
Standard Constant Pressure Range	1atm ± 10%
Recommended storage Temperature Range	0 to 20 degree C
Recommended Maximum Storage Time	6 months
Mechanical Data	
Enclosure Material	PPO
Enclosure Colour	Orchid Pink
Weight	2.6g
Total Volume	2.4 cm ³
Special Note: The output signal of the NAP-550 sensor is of negative polarity compared to (for example) CO and H₂S sensors.	



Dimensions and Materials of Construction:

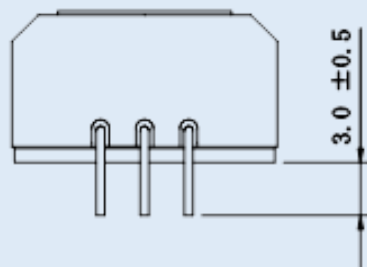
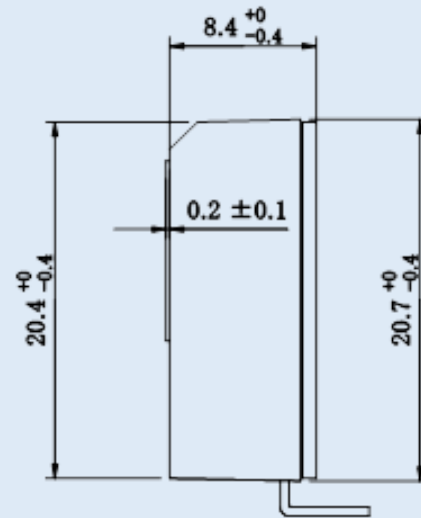
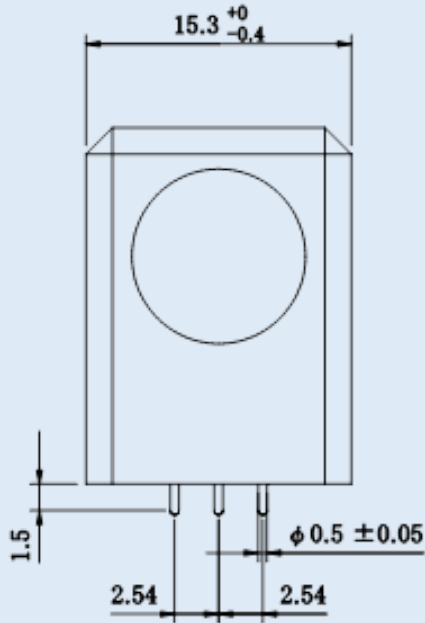

(Tolerance: ±0.2)

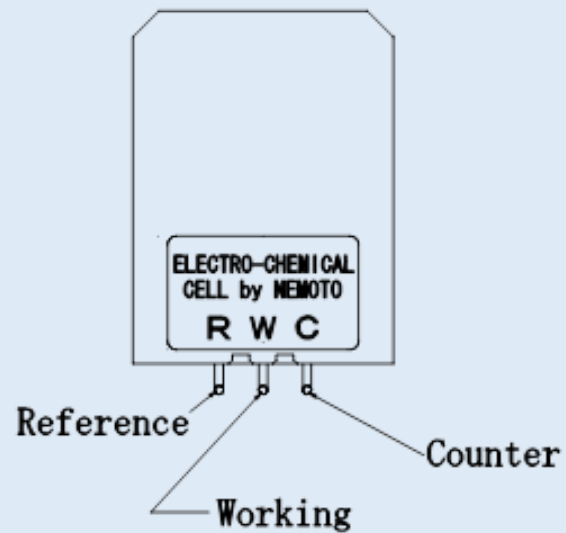

Case Material	PPO
Cap Color	Orchid Pink (Pre-filter : wine-red)
Weight	2.4 g (approx.)



Labelling and QR Code

The NAP-550 sensor is labelled at the front with a QR code, serial number and the finally tested NO₂ sensitivity measurement in nA/ppm NO₂. The labelling is as the below drawing:

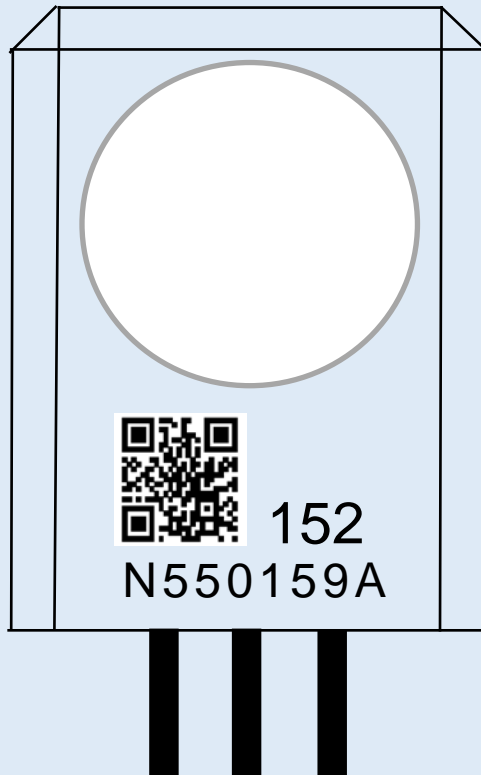

The Identification Number is in the following format, using the example above:

- N550 - Identifies the sensor as a NAP-550 type.
- 159 - Identifies the production month of the sensor, in this case September (9) 2015 (15).
October, November and December are signified by X, Y and Z.
- A - Identifies the production lot for the electrodes used in that sensor.

The QR Code is in the following format, again using the example above:

N550159A 21.0 X

152 signifies the sensitivity of the sensor, in nA/ppm, measured as part of Nemoto's final inspection procedure.

The X is for Nemoto internal use only, and may be any character.

The number (152) beside the QR code also signifies the sensitivity of the sensor, in nA/ppm, measured as part of Nemoto's final inspection procedure.

The QR code may be used as a convenient way of calibrating the sensor within the instrument electronically, without the need to expose the instrument to NO₂ test gas, as part of an automated production process.



Performance Measurements

Gas sensitivity

The Graph below shows the sensitivity characteristic:

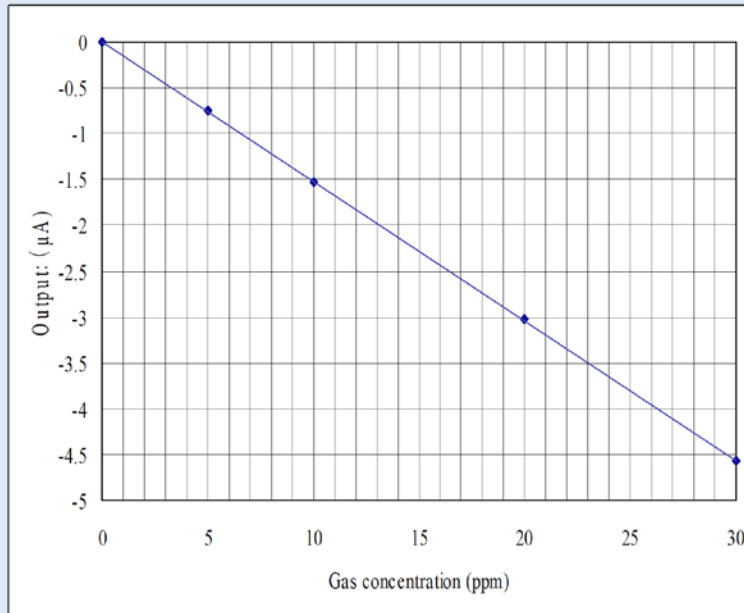

Cross Sensitivities to other Gases:

Test gas	% Cross-sensitivity compared to NO ₂ reading
Nitrogen Dioxide	100
Hydrogen	0
Methane	0
Iso-butane	0
Carbon dioxide	0
Sulfur dioxide	0
Hydrogen sulfide	-60
Nitrogen monoxide	0
Ammonia	0
Ethyl acetate	< 0.3
Toluene	< 2
Ethanol	0
Chlorine	< 100



Response Characteristics

The Figure below shows the typical response and recovery characteristics to 5 ppm NO₂ gas on the NAP-550.

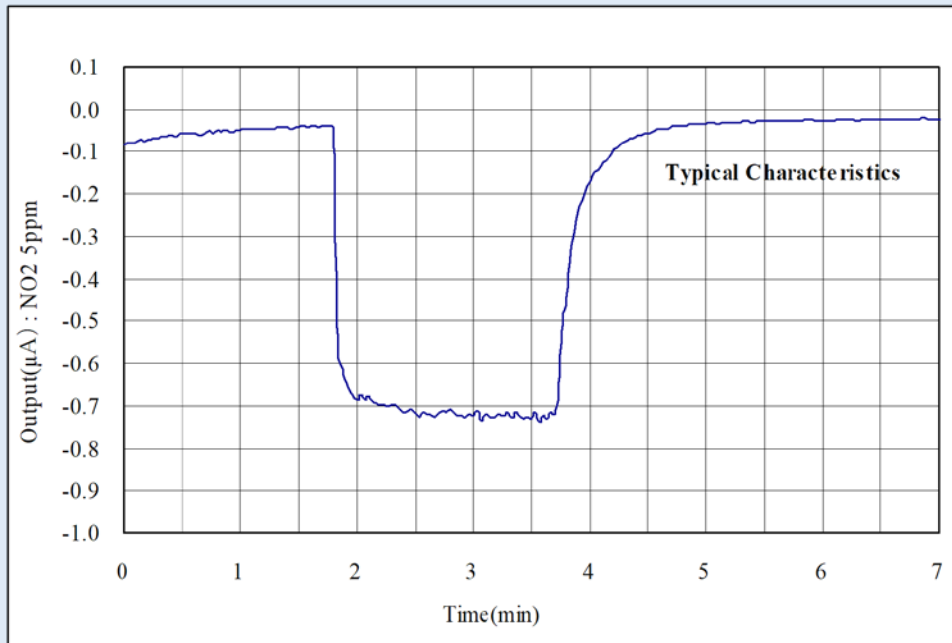

Temperature dependence

Effect on Signal Sensitivity: The figure below shows the mean variation of signal sensitivity with temperature, between -20 and +50 deg C. The value at 20 deg C is assumed to represent 100%. The instrument designer may decide that temperature correction is required for a particular application. Nemoto provides guidance on analogue temperature compensation circuits later in this manual.

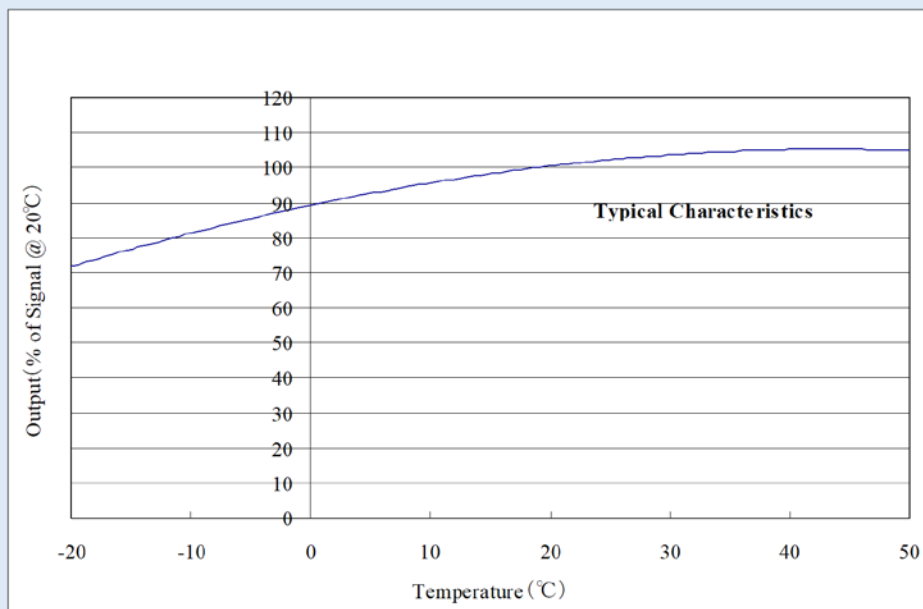



Recommended Circuitry

The basic measuring circuit for all 3-electrode electrochemical gas sensors is shown below:

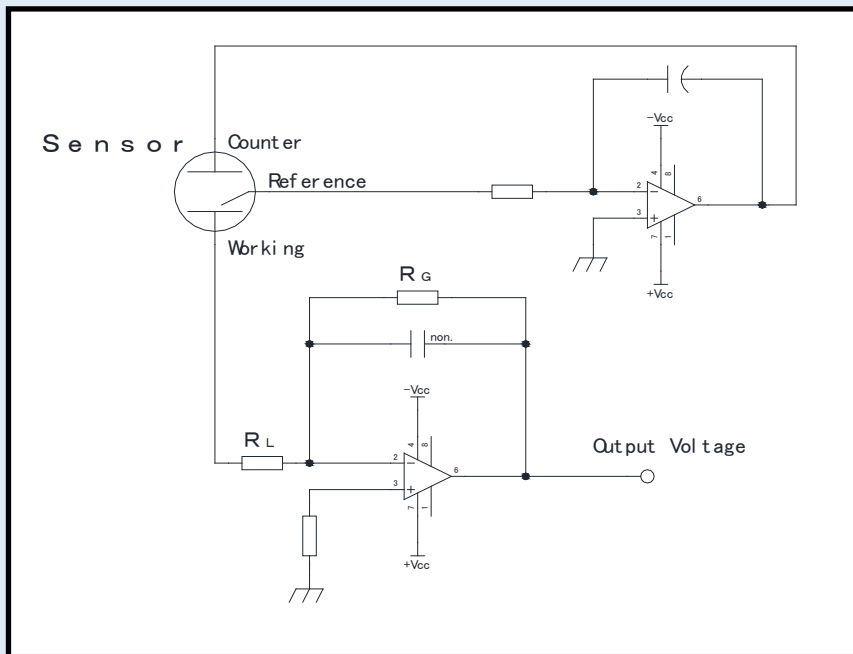

- In this arrangement, the output voltage =
$$\text{Gas Concentration (ppm)} \times \text{Cell Output (A)} \times R_G (\Omega)$$
- So if R_G is 10k, cell output is 150nA/ppm and gas concentration is 10ppm then
$$V_{OUT} = 10 \times (-150 \times 10^{-9}) \times (10 \times 10^3) = -0.015V$$
- R_L is the cell load resistor (typically 7.5-33 Ω). Speed of response can be increased by reducing the value of R_L , but signal noise may be increased as a consequence. The recommended values are shown on sensor datasheets
- Amplifiers should be high quality precision low input offset types, e.g. OP97 or similar
- Some sensors require temperature compensation circuitry. A simple compensation network can be incorporated into this circuit by replacing R_G with a thermistor. Typically this is a NTC thermistor that has 3435K of B constant adjusting the output accuracy to within $\pm 10\%$ in the range of $-10^\circ\text{C} \sim 50^\circ\text{C}$. Any thermistor with a B-constant around 3500K and resistance value (R_{25}) of 10 K Ω can be used. Alternatively, temperature compensation may be undertaken using software lookup tables.
- **Special Note: The output signal of the NAP-550 sensor is of negative polarity compared to (for example) CO and H₂S sensors.**



The circuit Nemoto employs for all its internal testing of NAP-550 is shown below:

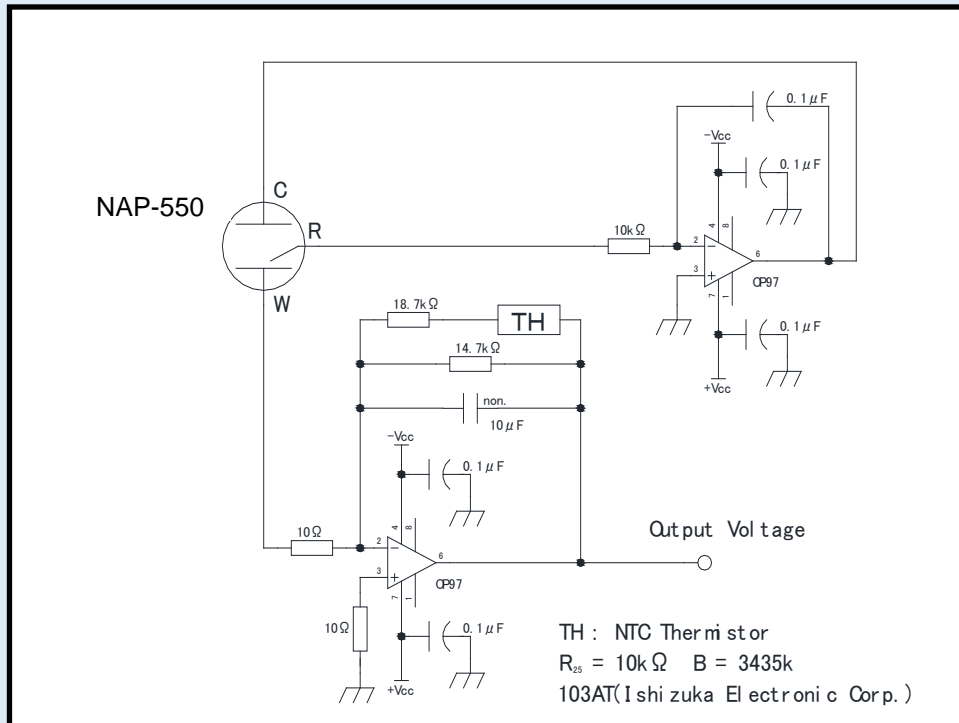

Nemoto recognises that the companies who use its gas sensing devices are themselves experts in circuitry design, often with more expertise than Nemoto in this area. The information given here is hence for initial guidance only, and Nemoto does not insist that instrument designers reproduce our circuitry guidance precisely. If the instrument designer deviates from this guidance significantly, however, Nemoto advises that we should be consulted to ensure that the proposed circuit design will function correctly.

Failure to adhere to the recommended circuitry outlined in this document without consultation with Nemoto may result in the suspension of the warranties which apply to the device.

GENERAL NOTES ON HANDLING, MANUFACTURE AND INSTRUMENT DESIGN

1) Long-term drift of gas sensitivity

All electrochemical gas sensors lose sensitivity over time due to small changes on the surface of the working electrode, reducing its oxidation capability. To reduce this, the NAP-550 uses a newly developed electrode catalyst that will not deteriorate by more than 10% / year. Typically, these changes are limited to less than 10% but we recommend that this deterioration should be taken into account when designing application circuits.

2) Environmental effects on gas sensitivity

Due to the hygroscopic nature of the electrolyte used in electrochemical sensors, moisture is absorbed from or released to the surrounding atmosphere. In high humidity moisture is absorbed, causing an increased sensitivity. In low



humidity moisture is released back to the atmosphere and the sensitivity decreases. Conventional electrochemical gas sensors show annual variation of gas sensitivity as much as 10 ~ 20%.

The NAP-550 utilises an advanced electrolyte management design and, combined with the unique electrode catalyst structure, these changes can be greatly reduced. Under normal operating conditions, gas sensitivity should change by no more than $\pm 5\%$ of the output value. The NAP-550 is designed so that all changes due to moisture uptake/release are completely reversible.

If the gas intake area of the sensor is blocked with water drops or other liquid, gas cannot enter the sensor. The NAP-550 is fitted with an integral hydrophobic barrier to prevent this, but we recommend the use of additional membrane barriers if the sensor in highly condensing RH conditions.

NO₂ gas is heavier than air, and will therefore fall to low levels in most applications. NO₂ detecting devices should be therefore be installed at low levels, provided it is safe to do so.

If the sensor is to be used in more irregular atmospheres, please contact us for assistance.

3) Storage of sensors

Electrochemical sensors should be stored in a clean air under room temperature, preferably 0°C ~ 20°C and in non-condensing RH conditions. The maximum storage period would be 6 months after delivery. For sensors stored for more than 6 months, the life in service will be shortened by the excess storage period. Unlike semiconductor type or hot-wire type gas sensors, the gas sensitivity of electrochemical gas sensors will change as time passes regardless of whether sensor has been used or not.

4) Mounting of sensors

Electrode pins must be connected correctly to ensure operation.

If a thermistor is used for temperature compensation, it must be located near the sensor and away from heat sources such as transformers.

The NAP-550 can be mounted in any orientation.

NAP-550 connection pins should not be soldered as excess heating may cause the deformation of the housing and eventually leakage of electrolyte.

5) Calibration and gas testing

Calibration of detectors or densitometers should be done after the output value has been stabilized in clean air.

Evaluation of gas sensitivity should be made with clean air as the balance gas. When a test gas is blown directly to the gas intake area, higher gas sensitivity may be observed. It is therefore best to test and calibrate gas detection instruments and sensors in diffusion mode. This can be achieved by using a suitable test housing where a low flow rate is used (<1l/min) and where the air is agitated to ensure equal gas diffusion throughout.

Note that Nemoto's own internal testing systems place the sensor in a large chamber, with the gas introduced by injection. The chamber includes a fan which gently agitates the gas inside the chamber to ensure the test gas is fully mixed with the air and does not stratify in the chamber. In this way, Nemoto's own testing very closely simulates the action of the sensor in a typical application.

Other methods, including the use of flow-through hoods and pumped sampling assemblies, may of course be used by instrument manufacturers, but it should be recognised that the method used to expose the sensor to test gas will have a small effect on the accuracy and repeatability of the results obtained, and the correlation of these results with Nemoto's own routine QA test results.



6) Other

Unless otherwise advised by Nemoto, voltage should not be supplied directly to the electrode pins.

Do not bend the pins.

Do not apply more than 5 Kg/cm² of force to the sensor.

Take care not to block the gas intake area as it may prevent gas entering the sensor.

Never put foreign material in the gas intake area as it may cause the electrolyte leakage

Do not expose the sensor to excess vibration or shock.

If the sensor housing is damaged, do not use the sensor.

If the sensor is exposed to a high concentration of the target gas for a long period, the output signal may require time to recover to normal operation.

Do not blow organic solvents, paints, chemical agents, oils, or high concentration gases directly onto sensors.

Do not disassemble the sensor as this may cause electrolyte leakage.

DEFINITIONS

Baseline / Baseline shift: Baseline means the output level in clean air. The output current value at 20°C would be less than +/-75nA, but this tends to change as the ambient temperature rises higher than 30°C. The Baseline shift means this variation of the output level, i.e. a maximum of 475nA, would be put out at 50°C. This baseline shift should be taken into account to optimise overall accuracy. In this manual, the output values are calculated to be equivalent to NO₂ gas concentrations.

Gas sensitivity / Output signals: Using the NAP-550, 150 ± 30nA is generated at 1ppm of NO₂ gas. For instance, the generated current value will be about 900nA at 10ppm of NO₂ gas (10ppm x 600nA). This generated current is generally recorded as a voltage produced by a Current – Voltage converting circuit as illustrated in our recommended circuit, as the conversion is done through a resistor of 10 KΩ.

Response time (T₉₀): This is the time taken to reach to 90% of the maximum output value in clean air.

Repeatability: This is the maximum variation of output signals when tests are repeated under the same measuring conditions (temperature, humidity, gas concentration etc.). The repeatability of NAP-550 is ± 2%, and this means that all of the test results would fall in the range of 98% ~ 102%.

Temperature dependence: All electrochemical sensors are affected by changes in the ambient temperature and the output increases as the ambient temperature rises. This is caused by the rate of oxidation reaction on the surface of the catalyst, the dispersibility of the gas in the capillary, and the thermal effects on the mobility of ions in the electrolyte. This temperature dependency can be compensated relatively easily by using a NTC thermistor.